

# DOOCH PUMP

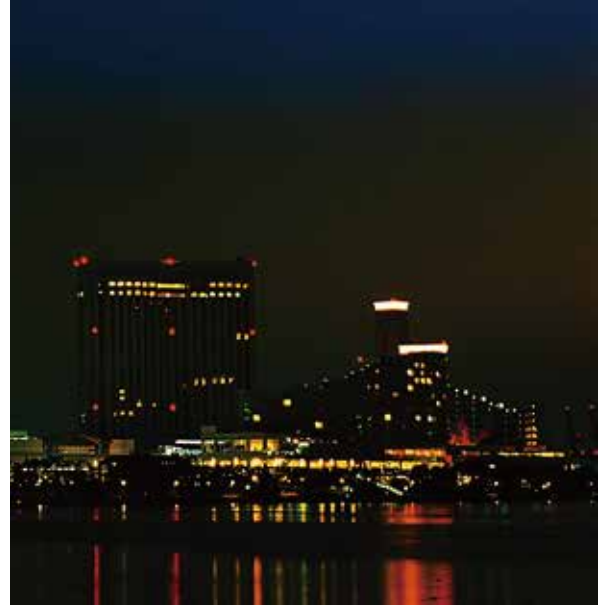

## IN-LINE CIRCULATION PUMP

## 50Hz DP SERIES



- District cooling system
- District heating system
- Industrial plants
- Air-conditioning system
- Water supply system
- Industrial cooling

**dooch**  
두크펌프  
[www.doochpump.com](http://www.doochpump.com)

# CONTENTS

## **DP SERIES** **IN-LINE CIRCULATION PUMP**

---

IN-LINE CIRCULATION PUMP .....	4
INVERTER IN-LINE CIRCULATION PUMP .....	6
DP 32 SERIES .....	14
DP 40 SERIES .....	16
DP 50 SERIES .....	18
DP 65 SERIES .....	20
DP 80 SERIES .....	22
DP 100 SERIES .....	24
DP 125 SERIES .....	26
DP 150 SERIES .....	28
DP 200 SERIES .....	30
DP 250 SERIES .....	32

GLOBAL PUMP SOLUTION DOOCH

50Hz



# IN-LINE CIRCULATION PUMP

DP, XQ-DP, NSQ-DP SERIES



## Feature

DP pumps are all single stage, inline centrifugal pumps equipped with a standard motor and a mechanical seal. Comparing with other pumps in similar structure, these pumps are less accessible to the impurity in the liquid.

The pumps are designed to be pulled out from the top when disassembled.

It can be repaired without affecting the pipelines.

The mechanical seal for DP200 and above is a cartridge mechanical seal. The DP pumps have the option to be equipped with Dooch's variable frequency drives (NSQ-DP, XQ-DP).

## Definition of the Model

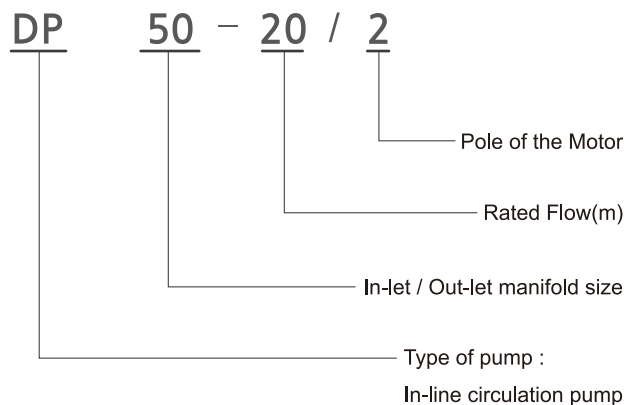

## Motor specification

Motor Type : TEFC

Protection class : IP55

Insulation class : F

Power Range : Below 7.5kW - 3phase 220/380V

Above 11kW - 3phase 380V

## Application

Cooling / heating system

Housing heating system

Air-conditioning system

Industrial water supply system

## Pumping Liquid

Thin, clean, non-explosive liquid, not containing solid particles or fibers

### Sectional Drawing(DP32 ~ DP150)

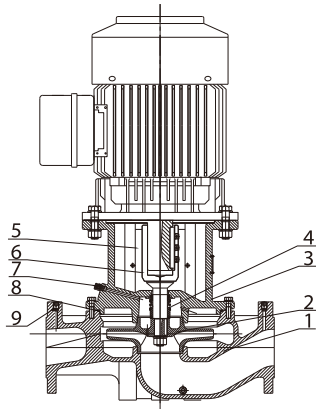

No.	PARTS	MATERIAL
1	Pump housing	Cast iron
2	Impeller	Cast iron
3	Pump head	Cast iron
4	Mechanical Seal	Carbon/Silicon carbide
5	Coupling Cover	Stainless steel
6	Shaft	Stainless steel
7	Air bolt	Brass
8	O-ring	NBR
9	Plug	Stainless steel

### Sectional Drawing(DP200 ~ DP250)

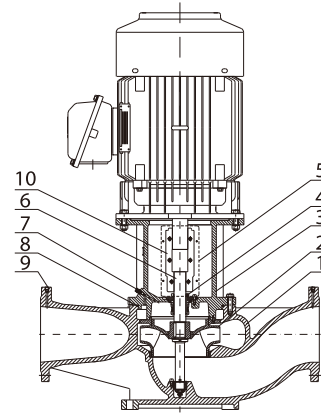

No.	PARTS	MATERIAL
1	Pump Housing	Cast iron
2	Impeller	Cast iron
3	Pump head	Cast iron
4	Mechanical Seal	Carbon/SIC, EPDM (Cartridge seal type)
5	Coupling Cover	Stainless steel
6	Shaft	Stainless steel
7	Air bolt	Brass
8	O-ring	NBR
9	Plug	Stainless steel
10	Coupling	Carbon steel

### Performance Range

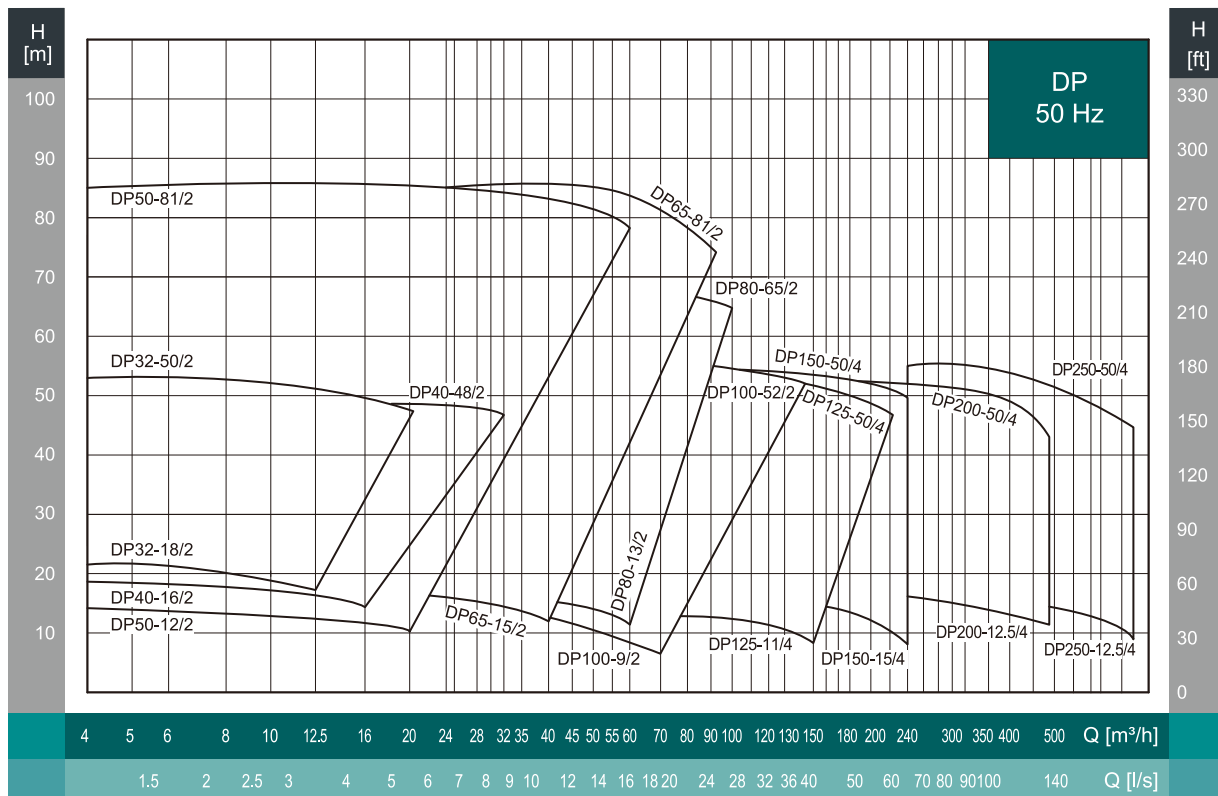

## Inverter In-line Pump

XQ-DP / NSQ-DP pumps are built on the basis of DP pumps.

Enhanced with the NSQ / XQ drives, the DP pump together with the appropriate sensor is turned into an intelligent, variable speed pumping system.

The NSQ / XQ drives adjust the speed of the motor to provide constant pressure or differential pressure to the flow rate.

## Operation

The system consists on an electric pump operated by an electronic control system(VFD) that deliveries constant pressure by reducing or increasing the flow rate based on the water demand.

In case of an excessive system pressure decrease, the VFD drive starts the pump and regulates its speed until the operating pressure is re-established.

The pump's speed depends on the water demand. If the water consumption increases, the control system raises the speed of the pump up to the max.set value. If there is no further water demand, the pump automatically stops.

## Application

- To control frequent water consumption
- To supply water with constant pressure
- To communicate pump with external comm.

## Benefits

- Energy saving (max 50%)
- Eliminates the need for seperate control panel, bypass lines and control valves
- Water hammar protection
- Soft start functionality to reduce the mechanical stress on pumping system
- Compact assembly and installation

## Energy Consumption Curve At Varying Pump Speed

If the pump speed decreases 20% depending on flow and head, the pump energy consumption decaede 50%.

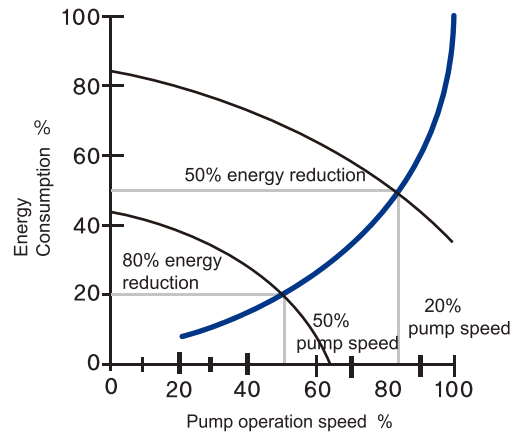

## Definition of model

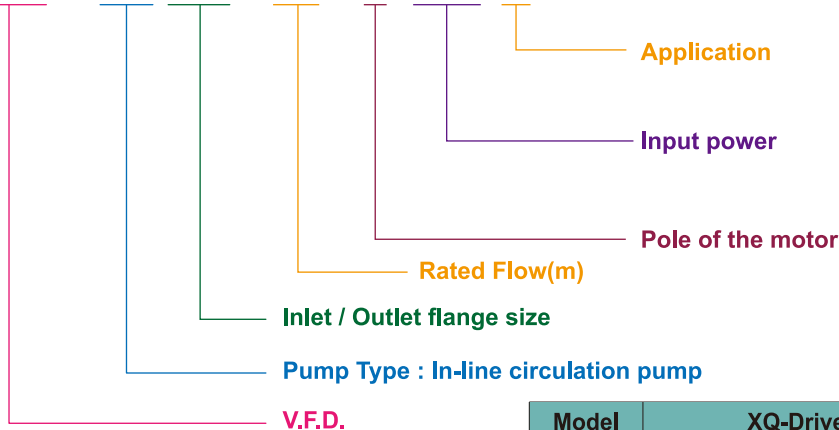

**NSQ - DP 50 - 20 / 2 (M) I**



I	Without I
Water supply	Circulation

M	Without M
Input power 1Φ×220V	Input power 3Φ×380V

2	4
2 pole	4 pole

Model	XQ-Drive	NSQ-Drive
Feature	 Built-in DC reactor and EMC filter provides optimal stability and the lowest possible energy consumption.	 Variable Frequency Drive mounted dedicated controller for pump

### Sectional Drawing(DP32 ~ DP150)

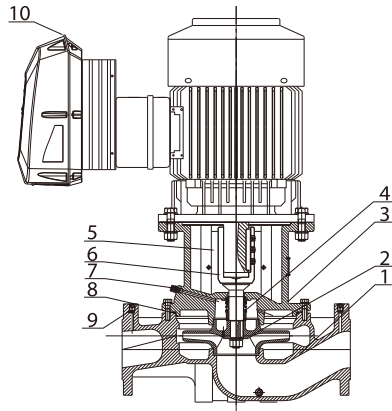

No.	PARTS	MATERIAL
1	Pump housing	Cast iron
2	Impeller	Cast iron
3	Pump head	Cast iron
4	Mechanical Seal	Carbon/Silicon carbide
5	Coupling Cover	Stainless steel
6	Shaft	Stainless steel
7	Air bolt	Brass
8	O-ring	NBR
9	Plug	Stainless steel
10	V.F.D.	XQ or NSQ Drive

### Sectional Drawing(DP200)

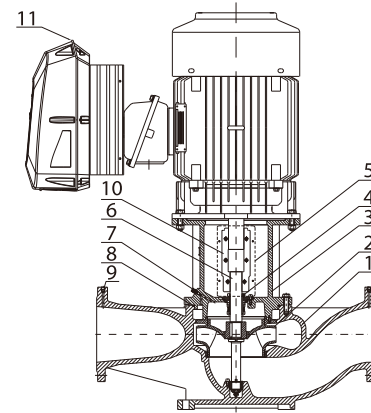

No.	PARTS	MATERIAL
1	Pump housing	Cast iron
2	Impeller	Cast iron
3	Pump head	Cast iron
4	Mechanical Seal	Carbon/SIC, EPDM (Cartridge seal type)
5	Coupling Cover	Stainless steel
6	Shaft	Stainless steel
7	Air bolt	Brass
8	O-ring	NBR
9	Plug	Stainless steel
10	Coupling	Carbon steel
11	V.F.D.	XQ or NSQ Drive

### Performance Range

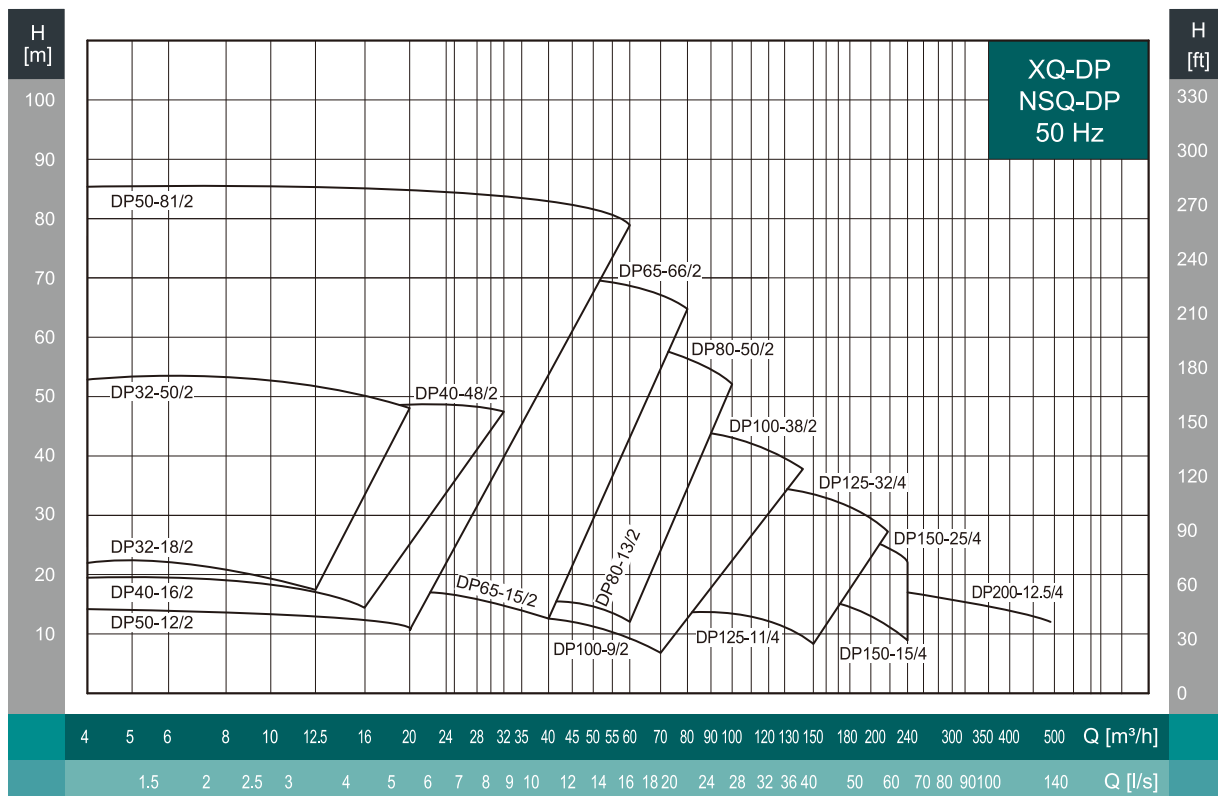

## Base Plate

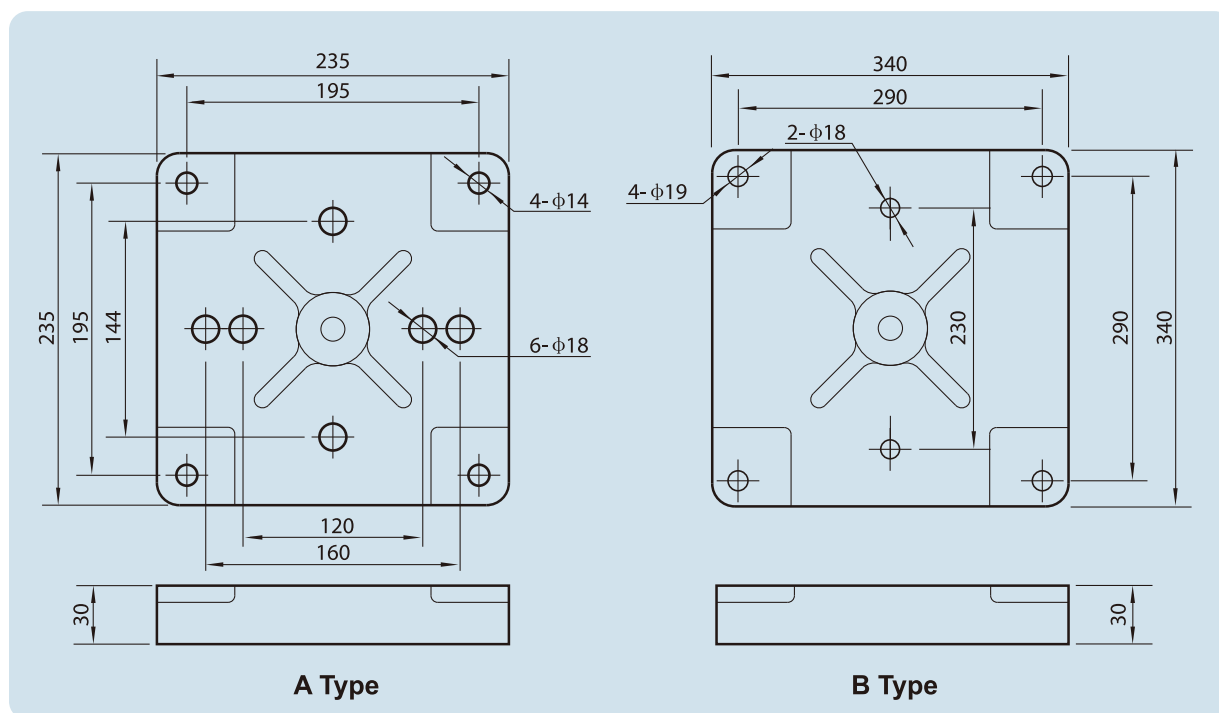

No.	MODEL	BASE PLATE TYPE	No.	MODEL	BASE PLATE TYPE	No.	MODEL	BASE PLATE TYPE
1	DP32-18/2	A	24	DP65-15/2	A	47	DP100-22/2	A
2	DP32-21/2	A	25	DP65-18/2	A	48	DP100-25/2	B
3	DP32-25/2	A	26	DP65-22/2	A	49	DP100-32/2	B
4	DP32-32/2	A	27	DP65-30/2	A	50	DP100-34/2	B
5	DP32-38/2	A	28	DP65-34/2	A	51	DP100-38/2	B
6	DP32-50/2	A	29	DP65-40/2	A	52	DP100-52/2	B
7	DP40-16/2	A	30	DP65-50/2	A	53	DP125-11/4	B
8	DP40-18/2	A	31	DP65-60/2	A	54	DP125-14/4	B
9	DP40-20/2	A	32	DP65-66/2	A	55	DP125-20/4	B
10	DP40-25/2	A	33	DP65-81/2	A	56	DP125-24/4	B
11	DP40-30/2	A	34	DP80-13/2	A	57	DP125-28/4	B
12	DP40-36/2	A	35	DP80-18/2	A	58	DP125-32/4	B
13	DP40-48/2	A	36	DP80-20/2	A	59	DP125-38/4	B
14	DP50-12/2	A	37	DP80-26/2	A	60	DP125-42/4	B
15	DP50-15/2	A	38	DP80-30/2	A	61	DP125-50/4	B
16	DP50-18/2	A	39	DP80-38/2	A	62	DP150-15/4	B
17	DP50-24/2	A	40	DP80-47/2	A	63	DP150-18/4	B
18	DP50-28/2	A	41	DP80-50/2	A	64	DP150-20/4	B
19	DP50-35/2	A	42	DP80-65/2	A	65	DP150-25/4	B
20	DP50-40/2	A	43	DP100-9/2	A	66	DP150-33/4	B
21	DP50-50/2	A	44	DP100-11/2	A	67	DP150-40/4	B
22	DP50-65/2	A	45	DP100-15/2	A	68	DP150-50/4	B
23	DP50-81/2	A	46	DP100-17/2	A	69		



## INSTALLATION REQUIREMENTS

Detailed requirements of installation

1. If the system pipeline can support the pumps, pumps with 2.2kW motor power(including 2.2kW) can be hung in line; if the system pipeline can not support the pumps or the pump motor power is higher than 2.2kW, the pumps must be installed in brackets or base.
2. Pump with motor power lower than 2.2kW(including 2.2kW) can be installed horizontally or vertically to the pipeline. Pumps with motor power higher than 2.2kW, can only be installed vertically to the pipeline. (see 2-A)
3. The pump installation shall not allow the system pipeline tensile force to be transferred to the pump body.
4. The pump should be installed in the environment with sufficient cooling and the cooling air shall not be above 40°C
5. If the pumps are installed outdoors, covers should be installed to protect electric components from water.
6. For the convenience of maintenance, there should be enough space above and below the pumps. (see 2-B).
7. To prevent noises and vibration and ensure the best operation, anti-vibration base shall be used in installation. Generally, cement base with the weight equal or bigger than 1.5 x pump weight shall be adopted.
8. The base is optional as the client's requirement. (Refer to the base lay-out for the dimension.)

For power  $\leq$  2.2kW

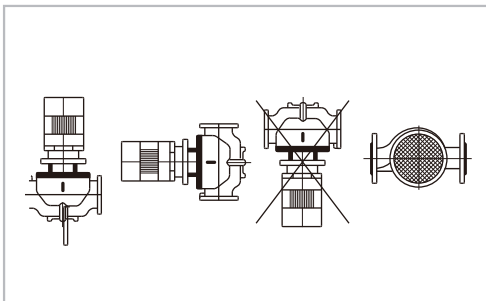

For power  $\geq$  5.5kW

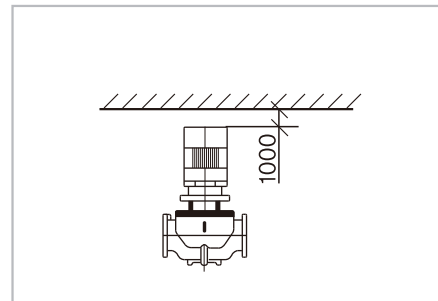

For power  $>$  2.2kW

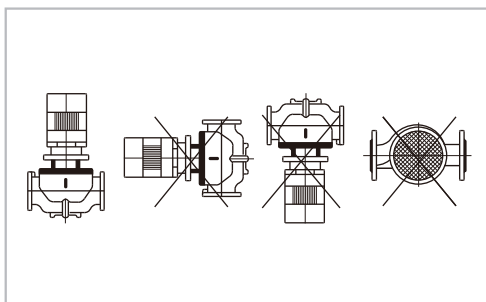

For power  $<$  5.5kW

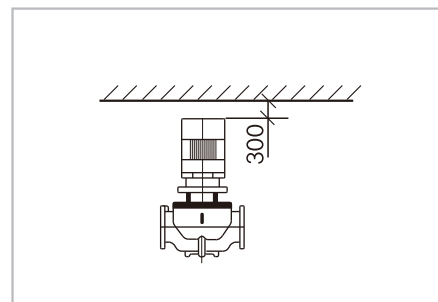

Pic. 2-A

Pic. 2-B

## XQ-DP

### Water Supply

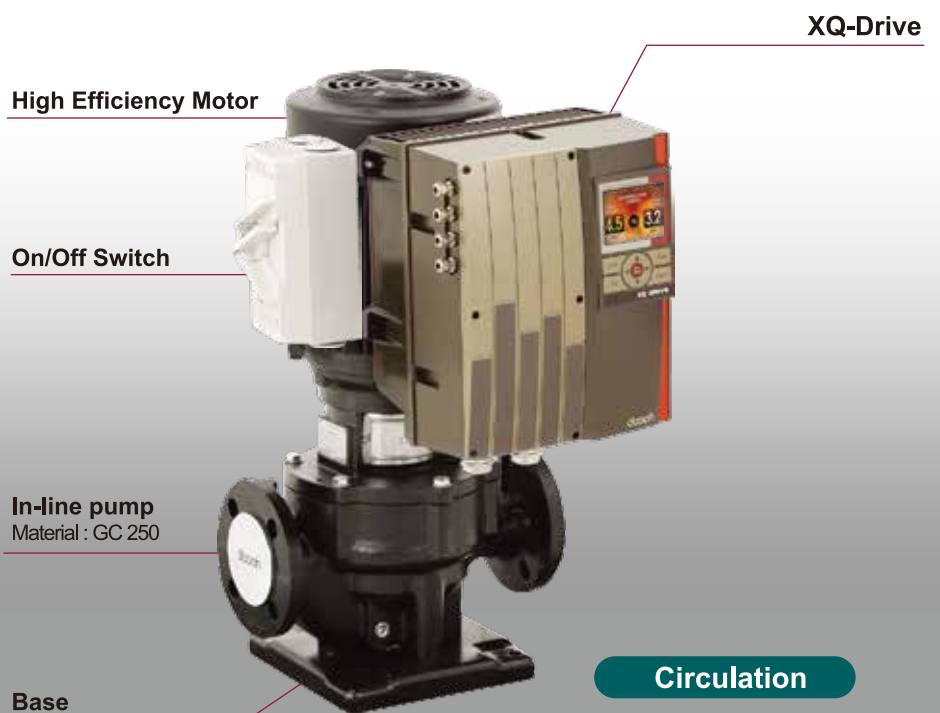

## XQ-DP features

XQ-DP pumps are built on the basis of DP pumps. Enhanced with XQ-Drive, the pump together with the appropriate sensor is turned into an intelligent, variable speed pumping system.

3.5" color display is able to provide the operating status of the pump and GUI(Graphical User Interface) is able for user to set the pressure easily.

## Specification

- Max. Flow : 480m<sup>3</sup>/h
- Max. Head : 84m
- Motor Power: 0.75~22kW (1~30HP)
- Input Power : 3Φ×380V / 50 & 60Hz

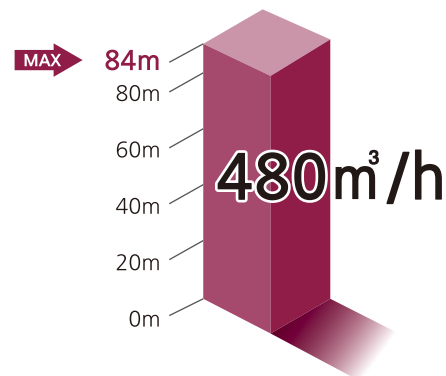

## Functions

- Control mode- pressure/differential pressure
- Pressure setting
- Dry-running protection
- Freezing protection
- Detect discharge flow-less automatically.
- Automatic recovery after power failure
- Protect pump and drive
- 3.5" color LCD
- Display operation status and RS-485 comm. (OPTION)

## XQ-DP benefit

- 3.5" color LCD
- Built-in EMC filter and DC reactor - Reduce noise and harmonic distortion
- Energy saving (MAX. 50%)
- Optimize the pump operation
- Water hammer protection and low noise operation
- Compact assembly and installation
- Eliminates the need for separate control panel, bypass lines and control valves.
- Extend the life of the pump
- Easy and convenient installation
- User friendly

## Main Components



In-line Pump  
DP Series



Premium V.F.D. for pump  
XQ-Drive



Pressure tank



Dedicated piping for  
inverter(Drive) pump

## NSQ-DP

### Water Supply

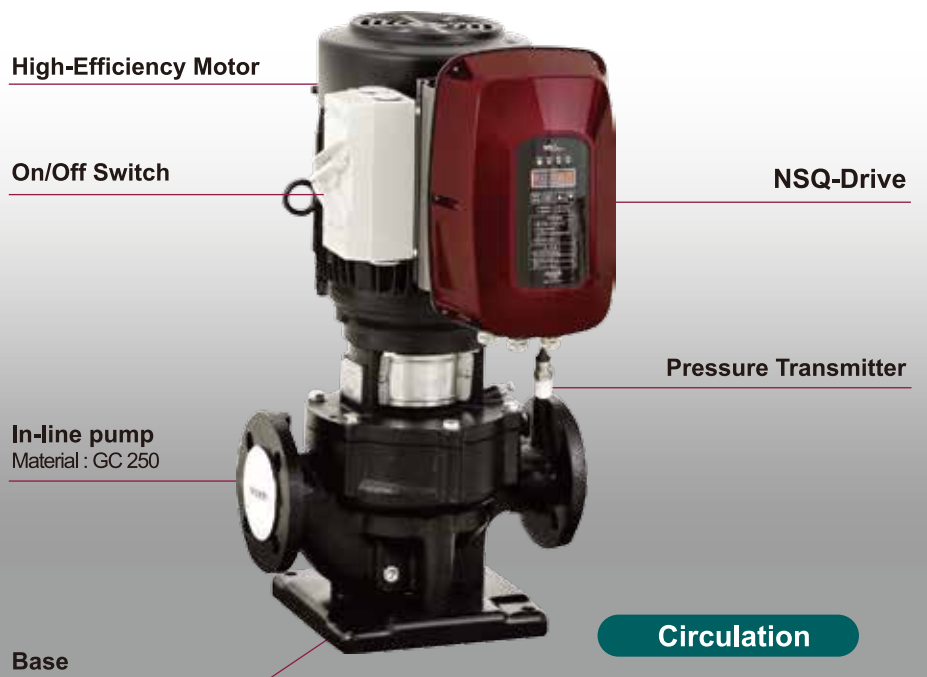

## NSQ-DP Features

NSQ-DP consist on an electric pump(DP pump)operated by an electronic control system(V.F.D.).

Comparing with DP pump, NSQ drive and DP pump together with the appropriate sensor is turned into an intelligent, variable speed pumping system.

## Specification

- Max. Flow : 480m<sup>3</sup>/h
- Max. Head : 84m
- Motor Power : 0.75~22kW (1~30HP)
- Input Power : 3Φ×380V / 50 & 60Hz  
1Φ×220V / 50 & 60Hz

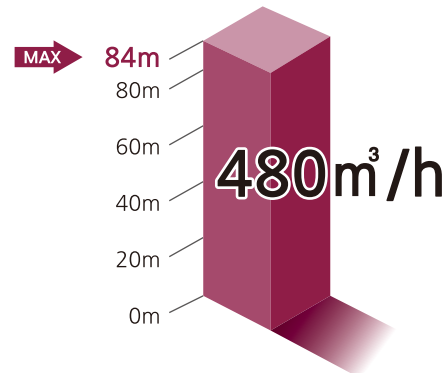

## Function

- Control Mode - Pressure/ differential pressure
- Set the setting pressure
- Dry-running and freeze protection
- Automatic Flowless Sensor
- Automatic recovery after power failure
- Inverter and Pump Protection
- FND- status monitoring

## NSQ-DP

- Energy saving (Max. 50%)
- Optimize the pump operation
- Water hammer protection / Low noise operation
- Compact assembly and installation
- Eliminate the need for separate control panel, bypass-lines and control valves.
- Extend life of the pump and motor
- Easy and convenient installation
- User friendly

## Main Components



In-line Pump  
DP Series



V.F.D. for pump  
NSQ-Drive



Pressure tank



Dedicated piping for  
inverter(Drive) pump

### Performance Curve

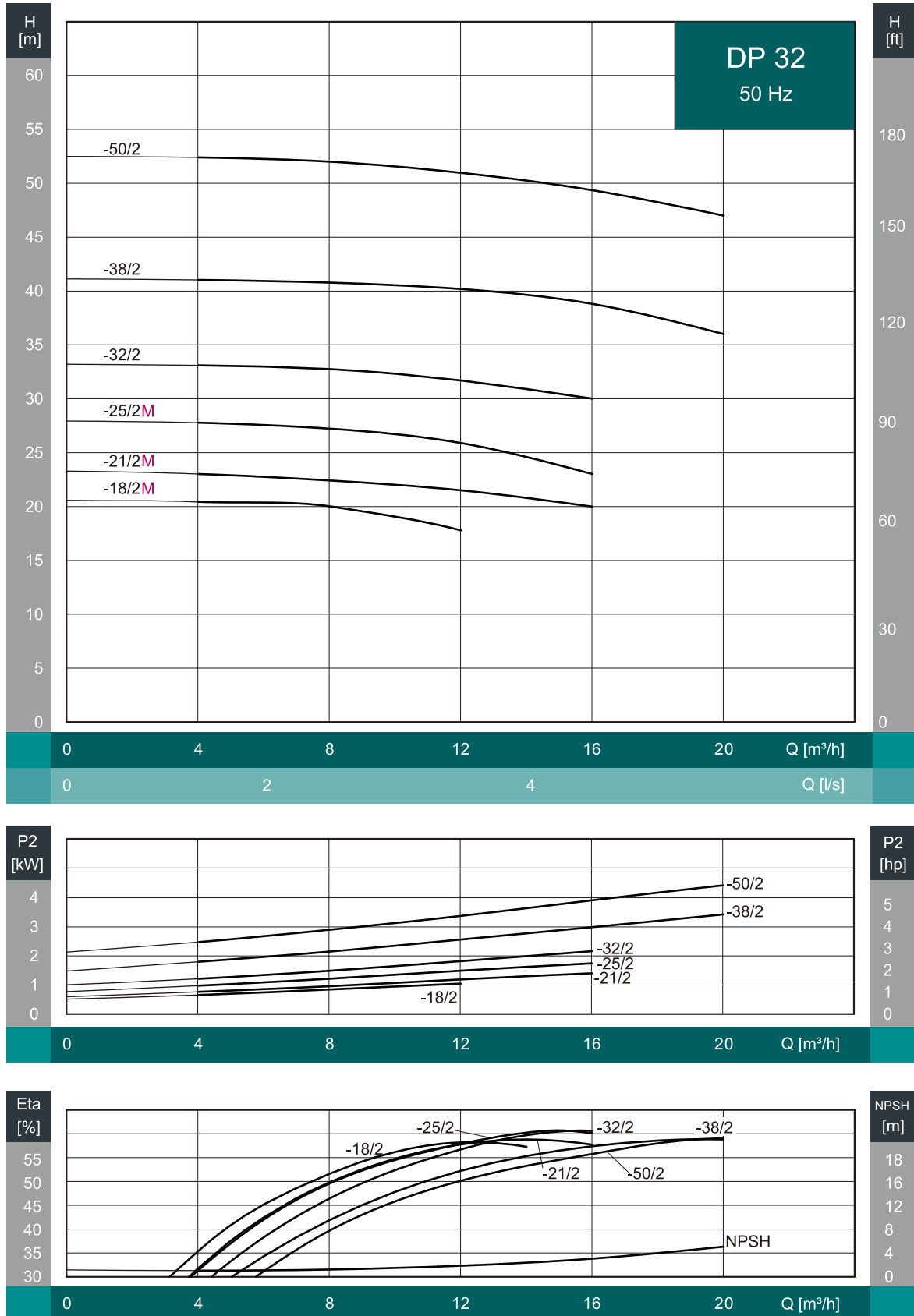

## Data Sheet

MODEL	POWER		Q (m <sup>3</sup> /hr)	4	8	12.5	16	20
	kW	HP						
DP32-18/2	1.1	1.5	HEAD (m)	19	18	17		
DP32-21/2	1.5	2		23	22	21	19	
DP32-25/2	2.2	3		28	27	26	23	
DP32-32/2	3	4		33.5	33	32	31	
DP32-38/2	4	5.5		41.5	41	40	37	36
DP32-50/2	5.5	7.5		51.8	51.5	51	49	47

## Installation Sketch

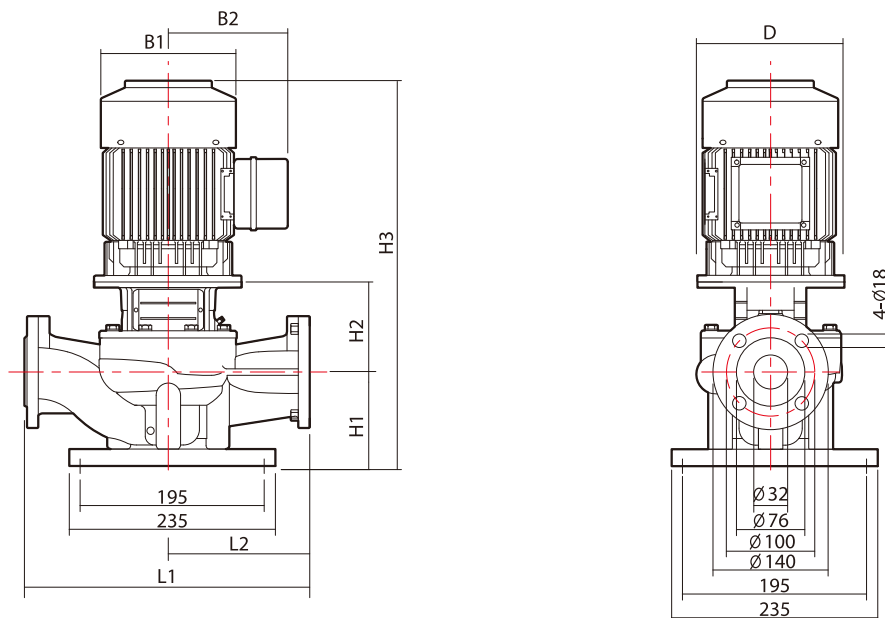

## Dimension / Weight

MODEL	DIMENSION (mm)								WEIGHT (kg)
	D	B1	B2	H1	H2	H3	L1	L2	
DP32-18/2	140	158	143	100	165.5	520.5	340	170	56
DP32-21/2	140	180	155	100	165.5	555.5	340	170	62
DP32-25/2	140	180	155	100	165.5	555.5	340	170	65
DP32-32/2	160	220	195	100	184.5	624.5	340	170	74
DP32-38/2	160	220	195	100	184.5	624.5	440	220	85
DP32-50/2	200	260	215	100	212.5	695.5	440	220	119

Remark | The motor specification is based on Dooch's standard motor.

### Performance Curve

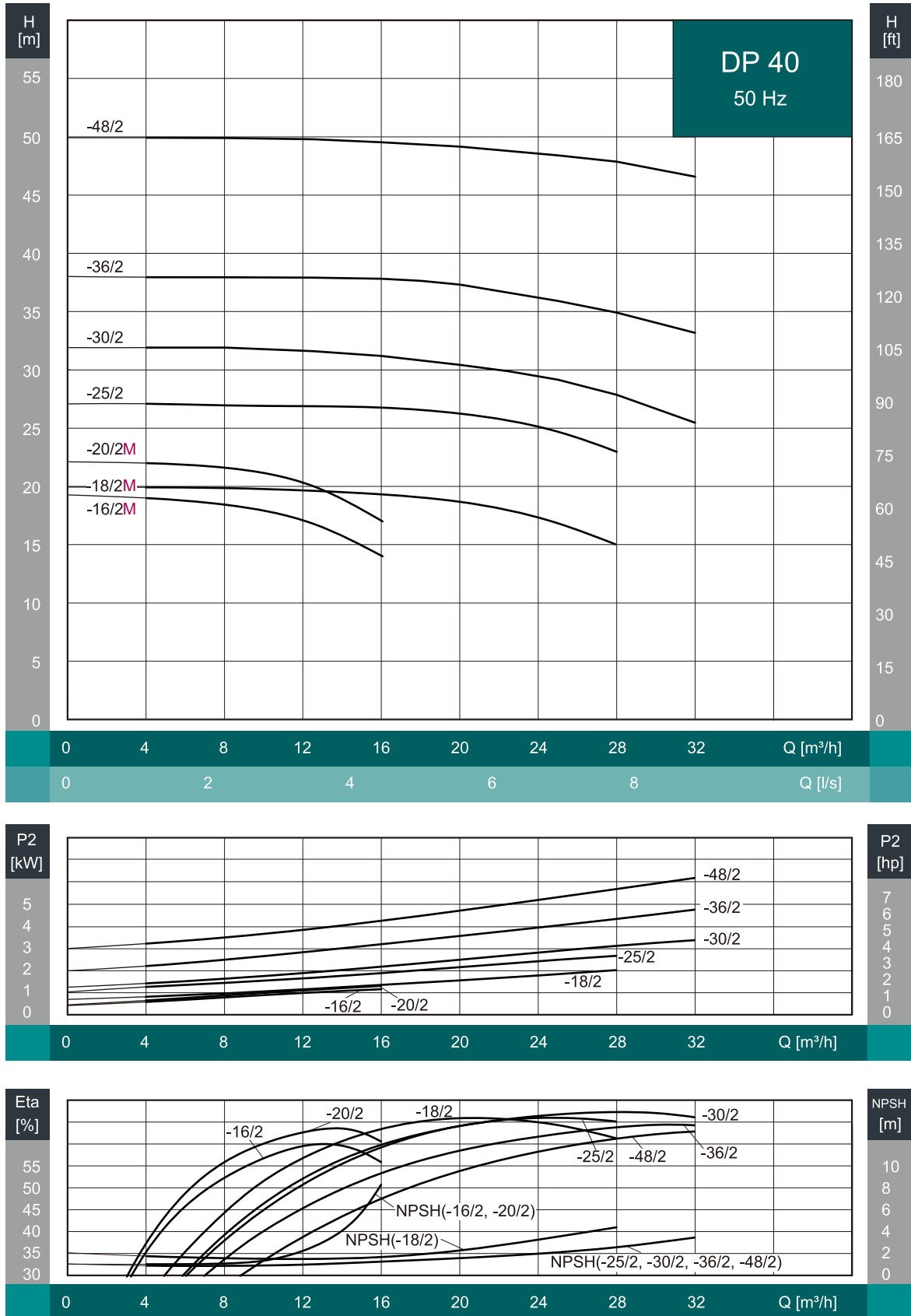



## Data Sheet

MODEL	POWER		Q (m <sup>3</sup> /hr)	4	8	12.5	16	20	25	28	32
	kW	HP									
DP40-16/2	1.1	1.5	HEAD (m)	19	18.5	17	14.5				
DP40-20/2	1.5	2		22	21	20	17				
DP40-18/2	2.2	3		21.5	21	20.5	20	19	17.5	16	
DP40-25/2	3	4		27.7	27.6	27.4	27	26	25	24	21
DP40-30/2	4	5.5		32	31.9	31.8	31.6	31	30	28	26
DP40-36/2	5.5	7.5		38.4	38.5	38.4	38.2	37	36	35	34
DP40-48/2	7.5	10		50.6	50.3	50.1	50	49	48	47	46

## Installation Sketch

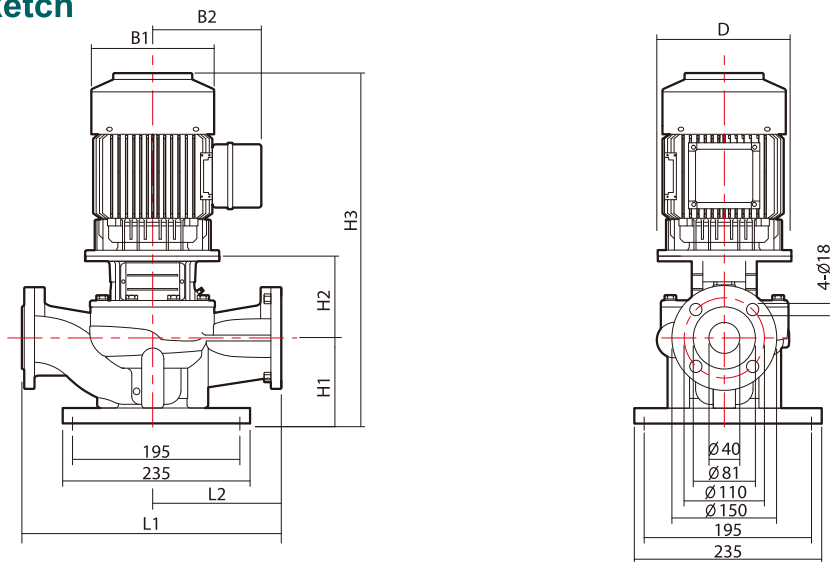

## Dimension / Weight

MODEL	DIMENSION (mm)								WEIGHT (kg)
	D	B1	B2	H1	H2	H3	L1	L2	
DP40-16/2	122	158	143	68	150	473	320	160	46
DP40-20/2	140	180	155	68	160	518	320	160	52
DP40-18/2	140	180	155	100	165.5	555.5	340	170	59
DP40-25/2	160	220	195	100	184.5	624.5	340	170	76
DP40-30/2	160	220	195	100	184.5	624.5	340	170	83
DP40-36/2	200	260	215	110	212.5	705.5	440	220	121
DP40-48/2	200	260	215	110	212.5	705.5	440	220	125

Remark | The motor specification is based on Dooch's standard motor.

### Performance Curve

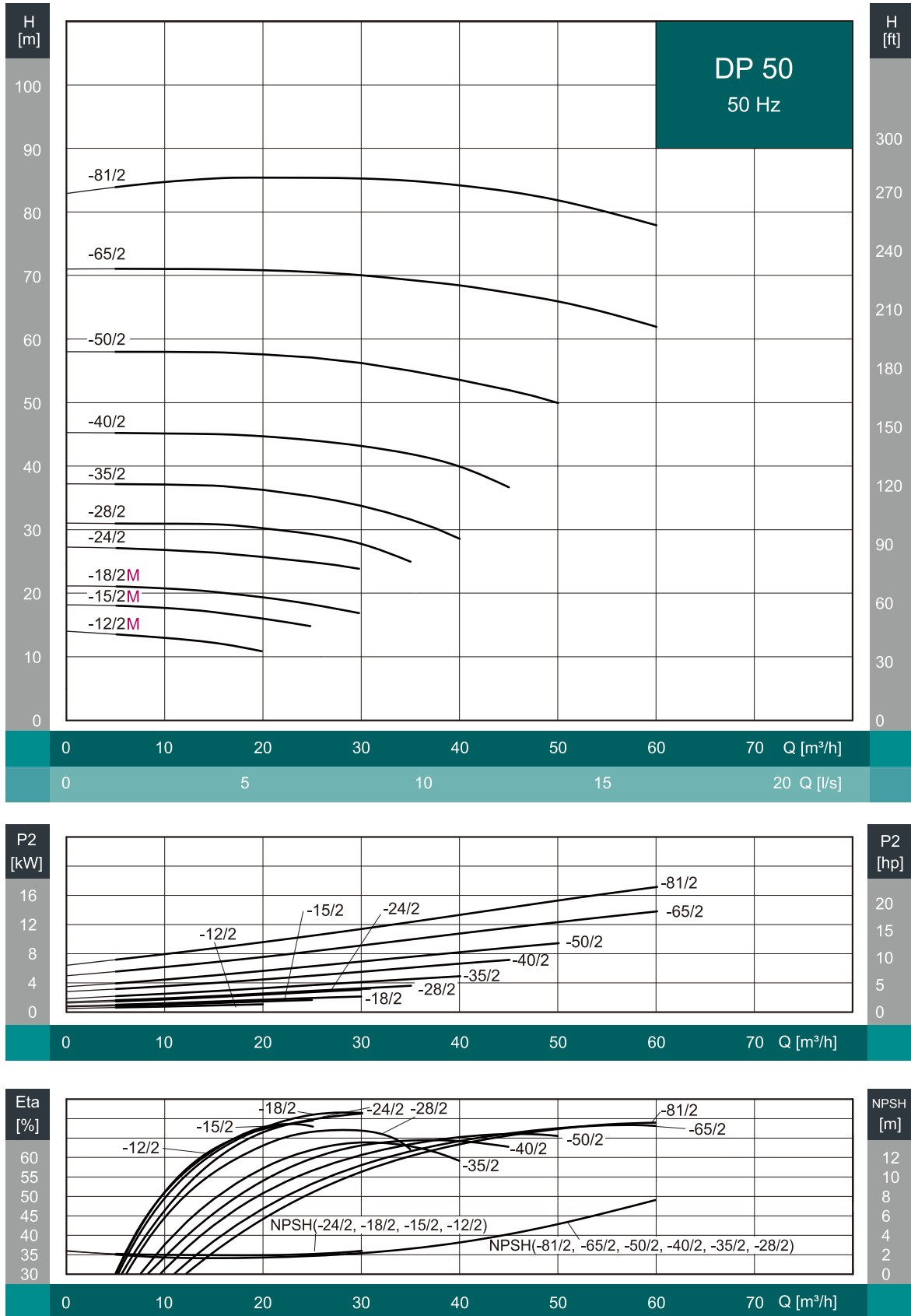

### Data Sheet

MODEL	POWER		Q (m <sup>3</sup> /hr)	5	10	15	16	20	25	30	35	40	45	50	55	60
	kW	HP														
DP50-12/2	1.1	1.5	HEAD (m)	14	13.5	13	12	11	10							
DP50-15/2	1.5	2		18	17.8	17.2	17	16	15							
DP50-18/2	2.2	3		21	20.7	20.2	20	19	18	17						
DP50-24/2	3	4		27	26.8	26.4	26	25	24	23	22					
DP50-28/2	4	5.5		31.7	31.5	31.2	31	30	29	28	25					
DP50-35/2	5.5	7.5		37.6	37.5	37.1	37	36.5	36	35	32	28	24			
DP50-40/2	7.5	10		45.8	45.7	45.5	45.3	45	44	43.5	42	40	37			
DP50-50/2	11	15		58	58.5	58.6	58.5	58	57	56	55	53	52	49	46	
DP50-65/2	15	20		70	71.15	71.4	71.5	71.3	70.98	70	69	68	67.5	66	64	62
DP50-81/2	18.5	25		83.2	83.7	84	84.2	84.4	84.5	84	83.5	83	82	81	79	77

### Installation Sketch

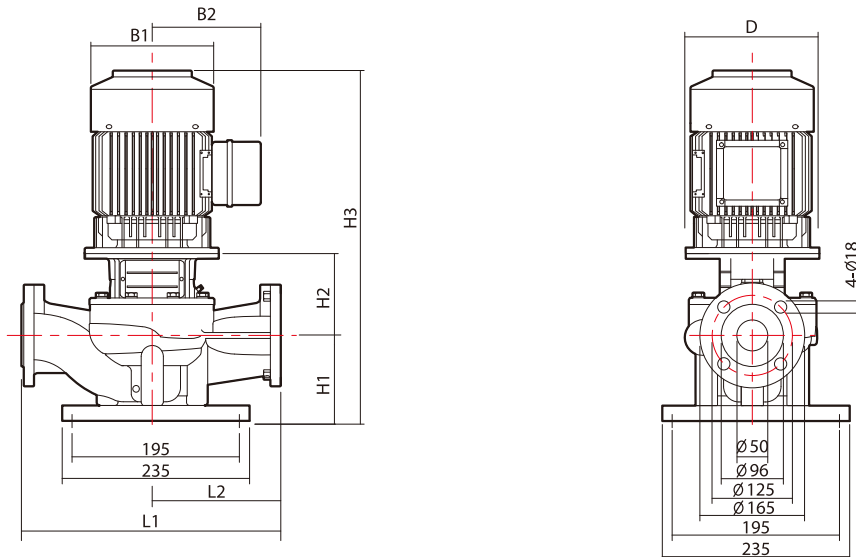

### Dimension / Weight

MODEL	DIMENSION (mm)								WEIGHT (kg)
	D	B1	B2	H1	H2	H3	L1	L2	
DP50-12/2	140	158	143	115	153	523	340	170	62
DP50-15/2	140	180	155	115	153	558	340	170	68
DP50-18/2	140	180	155	115	153	558	340	170	71
DP50-24/2	160	220	195	115	172	627	340	170	80
DP50-28/2	160	220	195	115	174.5	629.5	340	170	85
DP50-35/2	200	260	215	115	196.5	694.5	340	170	118
DP50-40/2	200	260	215	115	187	685	440	220	133
DP50-50/2	350	320	260	115	250	870	440	220	199
DP50-65/2	350	320	260	115	250	870	440	220	209
DP50-81/2	350	320	260	115	250	925	440	220	267

Remark | The motor specification is based on Dooch's standard motor.

### Performance Curve

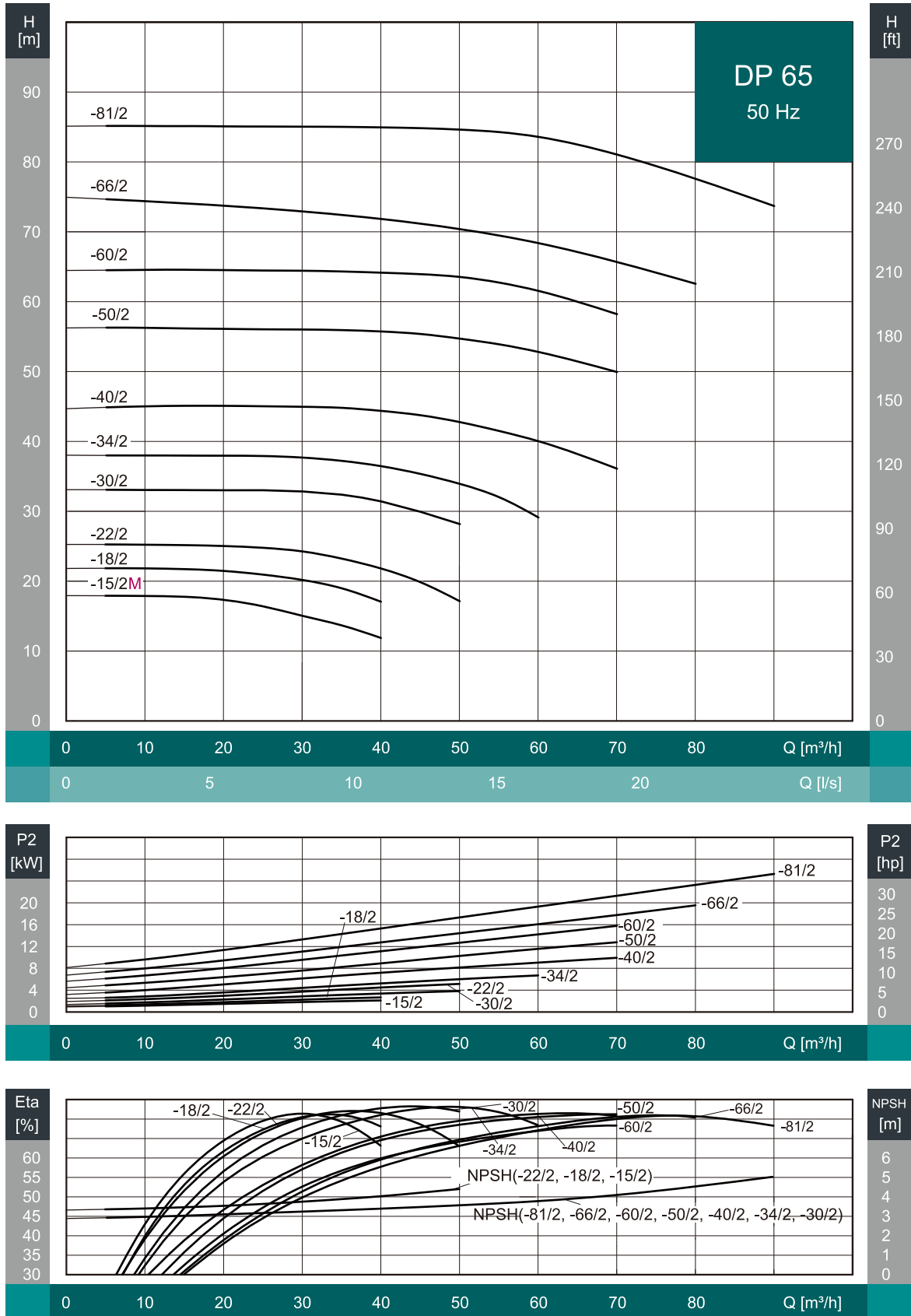

### Data Sheet

MODEL	POWER		Q (m <sup>3</sup> /hr)	HEAD (m)																
	kW	HP		5	10	15	16	20	25	30	35	40	45	50	55	60	70	80	90	
DP65-15/2	2.2	3		18.1	18.2	18	17.5	17	16	15	14	12								
DP65-18/2	3	4		22	21.9	21.7	21.6	21.5	21	20	18	17								
DP65-22/2	4	5.5		26	26.1	26	25.9	25.8	25.5	24.5	24	22	20	17						
DP65-30/2	5.5	7.5		33.4	33.5	33.6	33.5	33.4	33.2	33	32	31	29	28	26	23				
DP65-34/2	7.5	10		38.2	38.3	38.5	38.4	38.3	38	37.5	37	36	35	34	32	29				
DP65-40/2	11	15		44	45	45.3	45.5	45.7	45.6	45.5	45	44	43	42	40	39	37			
DP65-50/2	15	20		55	56	56.5	56.6	56.7	56.6	46.4	56	55.5	55	52	50	48	46			
DP65-60/2	18.5	25		64	64.5	64.7	64.8	65	65.1	65	64.8	64.5	64	63	62	61	59			
DP65-66/2	22	30		72	72.8	73	73.5	74	74.2	74	73.8	73.5	72	71	70	68	65	63		
DP65-81/2	30	40		84	85	85.5	85.6	85.7	85.8	85.9	85.8	85.5	85	84.5	84	83	81	79	74	

### Installation Sketch

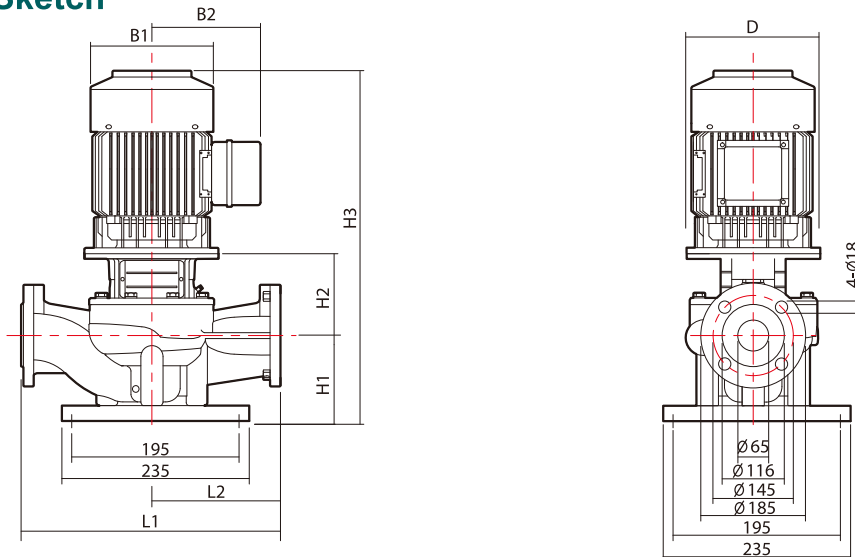

### Dimension / Weight

MODEL	DIMENSION (mm)								WEIGHT (kg)
	D	B1	B2	H1	H2	H3	L1	L2	
DP65-15/2	140	180	155	105	172	567	340	170	62
DP65-18/2	160	220	195	105	191	636	340	170	68
DP65-22/2	160	220	195	105	191	636	340	170	71
DP65-30/2	200	260	215	105	213	701	340	170	80
DP65-34/2	200	260	215	105	213	701	340	170	85
DP65-40/2	350	320	260	125	262	892	475	237.5	118
DP65-50/2	350	320	260	125	262	892	475	237.5	133
DP65-60/2	350	320	260	125	262	947	475	237.5	199
DP65-66/2	350	355	280	125	262	965	475	237.5	209
DP65-81/2	400	400	305	125	262	1047	475	237.5	227

Remark | The motor specification is based on Dooch's standard motor.

### Performance Curve

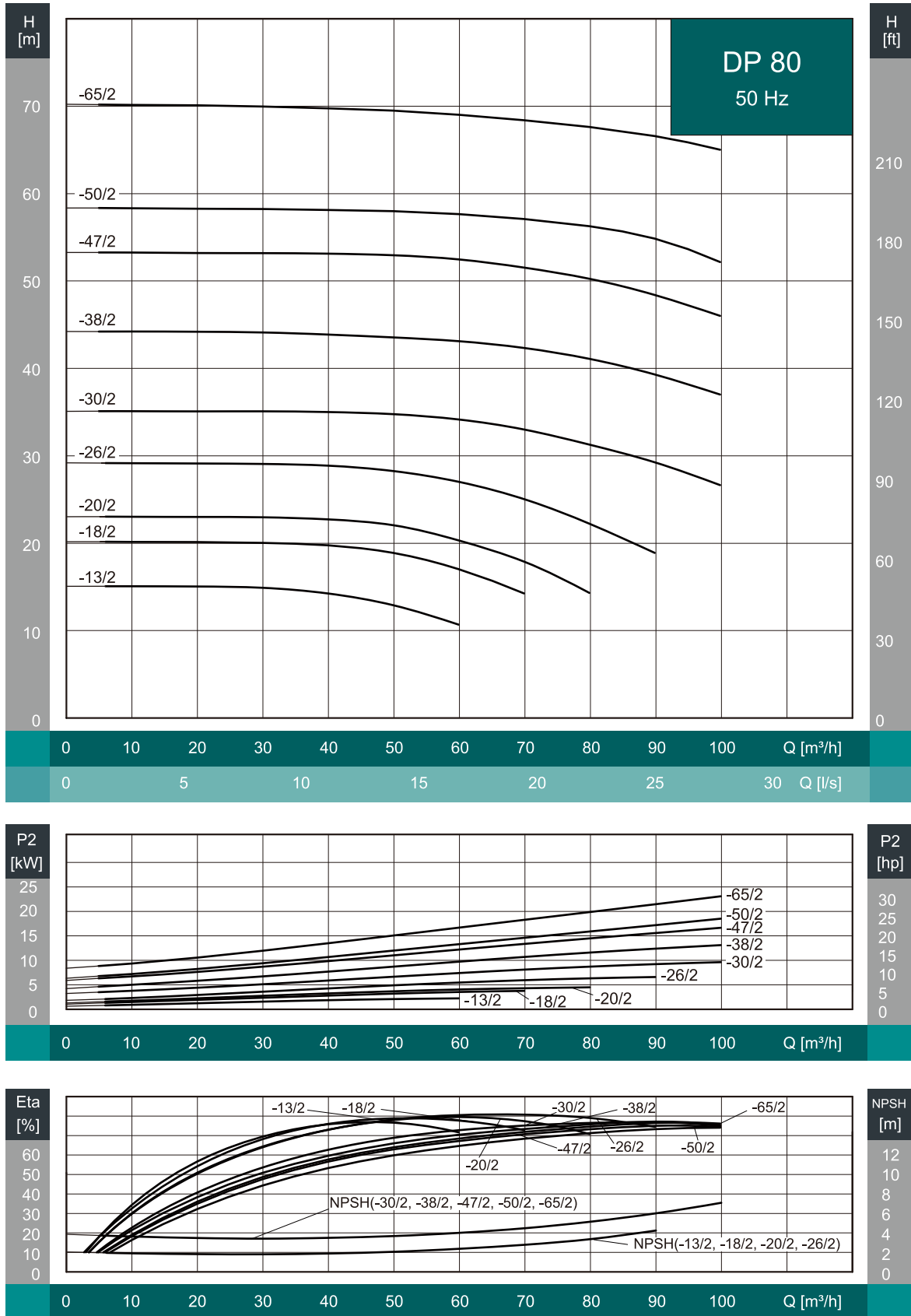

### Data Sheet

MODEL	POWER		Q (m <sup>3</sup> /hr)	HEAD (m)												
	kW	HP		5	10	20	30	40	50	60	70	80	90	100	110	120
DP80-13/2	3	4	15	15.7	16	15	14	13	10							
DP80-18/2	4	5.5	20	20.3	20.6	20.5	20	19	17	14	11					
DP80-20/2	5.5	7.5	23	23.4	23.6	23.5	23	22	20	18	14					
DP80-26/2	7.5	10	29.3	29.5	29.7	30	29	28	27	25	22	19				
DP80-30/2	11	15	35.3	35.4	35.5	35.4	35	34	33.5	33	31	29	27			
DP80-38/2	15	20	44	44.2	44.5	44.3	44	43.5	43	42	41	40	37			
DP80-47/2	18.5	25	53	53.3	53.5	53.4	53	52.5	52	51	50	48	46			
DP80-50/2	22	30	58.2	58.4	58.6	58.5	58.4	58	57.8	57	56	54	53	48	43	
DP80-65/2	30	40	69.5	69.6	69.8	70	69.9	69.7	69	68	67	66	65	62	59	

### Installation Sketch

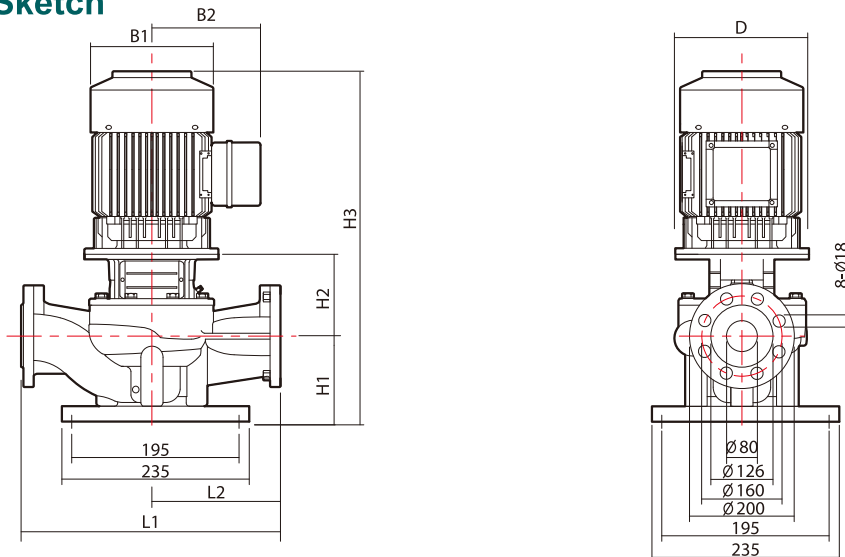

### Dimension / Weight

MODEL	DIMENSION (mm)								WEIGHT (kg)
	D	B1	B2	H1	H2	H3	L1	L2	
DP80-13/2	160	220	195	97	219	656	450	225	90
DP80-18/2	160	220	195	97	219	656	450	225	97
DP80-20/2	200	260	215	97	241	721	450	225	120
DP80-26/2	200	260	215	97	241	721	450	225	123
DP80-30/2	350	320	260	115	279	899	500	250	200
DP80-38/2	350	320	260	115	279	899	500	250	210
DP80-47/2	350	320	260	115	279	954	500	250	228
DP80-50/2	350	355	280	115	279	972	500	250	264
DP80-65/2	400	400	305	115	279	1054	500	250	325

Remark | The motor specification is based on Dooch's standard motor.

### Performance Curve

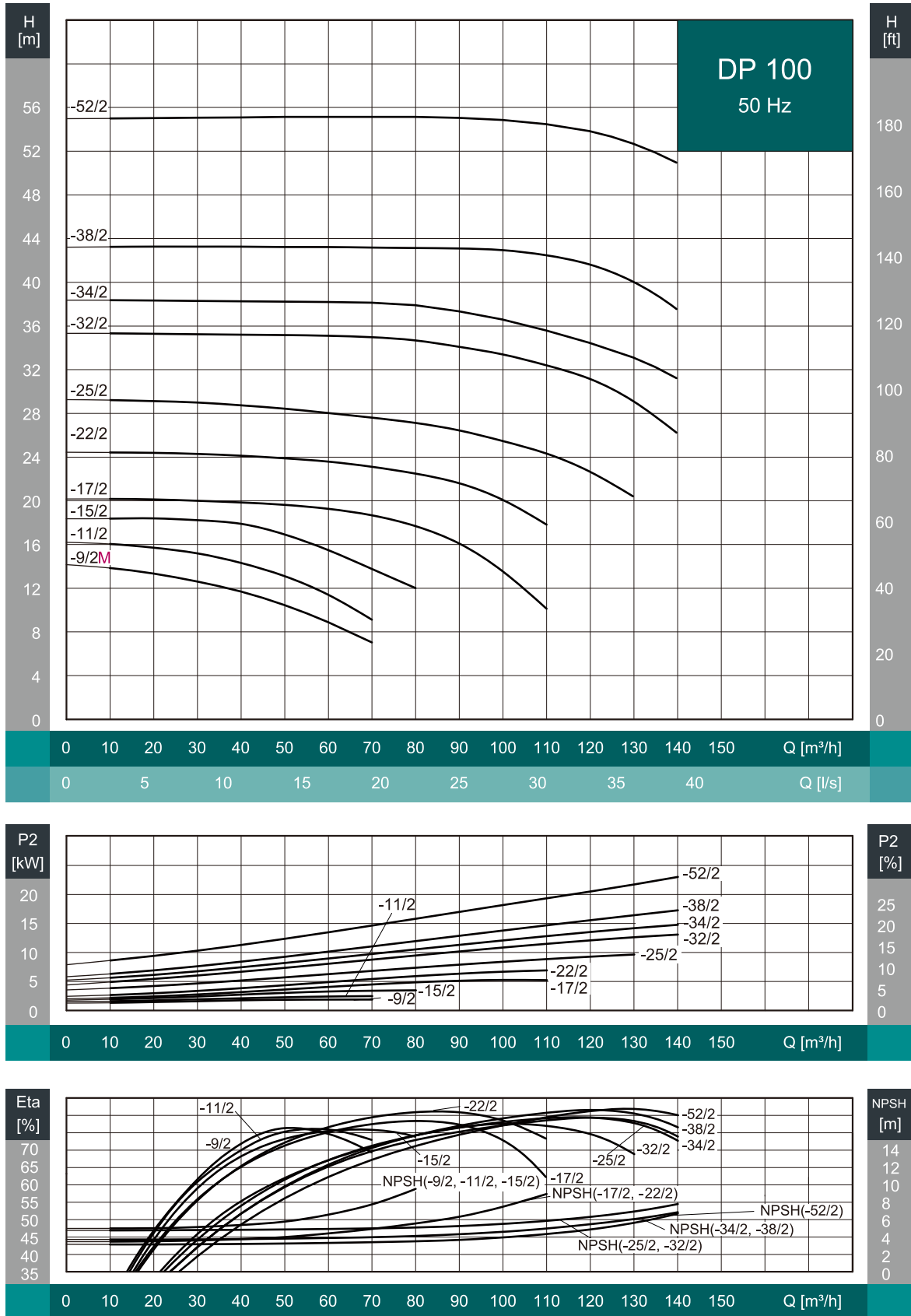



## Data Sheet

MODEL	POWER		Q (m <sup>3</sup> /hr)	HEAD (m)															
	kW	HP		10	20	30	40	50	60	70	80	90	100	110	120	130	140	150	160
DP100-9/2	2.2	3		13	13	12	11	10	8	7									
DP100-11/2	3	4		15	15.5	14.5	14	13	11	10									
DP100-15/2	4	5.5		18.9	18.5	18.6	18	17	15	14	12								
DP100-17/2	5.5	7.5		20	20.5	19.8	19.7	19.6	19.4	19	18	16	14	11					
DP100-22/2	7.5	10		24	24.2	24.1	24	23.8	23.5	23	22	21	20	17					
DP100-25/2	11	15		28.5	29	28.8	28.5	28	27.7	27.5	27	26	25	24	22	20			
DP100-32/2	15	20		35.3	35.5	35.6	35.5	35.3	35	34.5	34	33.5	33	32	31	29	26		
DP100-34/2	18.5	25		37	38	38.1	38.3	38.2	38	37.8	37.5	37	36	35	34	33	31	28	
DP100-38/2	22	30		44	44.5	44.7	44.9	45	45	44.9	44.7	44.5	44	42	41	37	36	33	
DP100-52/2	30	40		54.5	54.5	54.5	54.5	54	54	54.8	54.8	54.9	55	54.8	54.5	53	51	46	40

## Installation Sketch

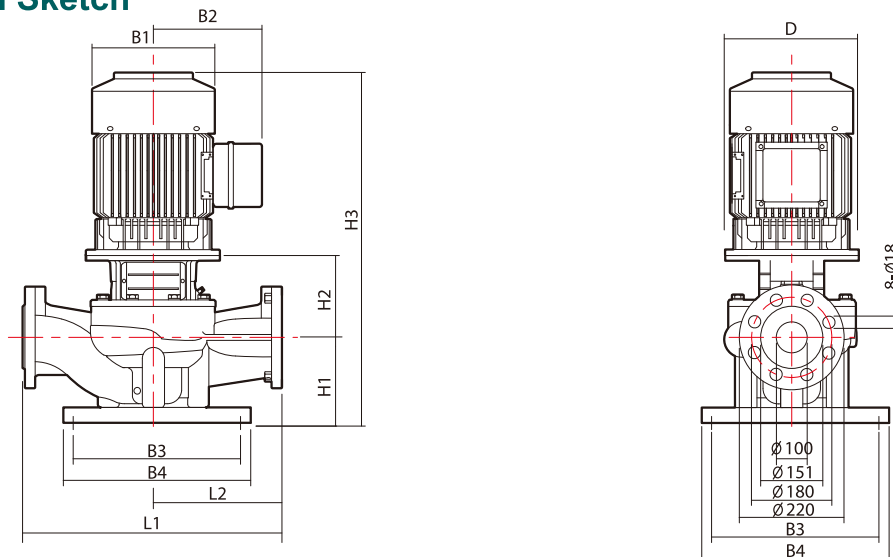

## Dimension / Weight

MODEL	DIMENSION (mm)										WEIGHT (kg)
	D	B1	B2	B3	B4	H1	H2	H3	L1	L2	
DP100-9/2	140	180	155	195	235	107	171.5	568.5	450	225	80
DP100-11/2	160	220	195	195	235	107	189.5	636.5	450	225	97
DP100-15/2	160	220	195	195	235	107	189.5	636.5	450	225	98
DP100-17/2	200	260	215	195	235	140	215	738	500	250	137
DP100-22/2	200	260	215	195	235	140	215	738	500	250	140
DP100-25/2	350	320	260	290	340	140	270	915	550	275	219
DP100-32/2	350	320	260	290	340	140	270	915	550	275	229
DP100-34/2	350	320	260	290	340	140	270	970	550	275	246
DP100-38/2	350	355	280	290	340	140	270	988	550	275	285
DP100-52/2	400	400	305	290	340	140	270	1070	550	275	343

Remark | The motor specification is based on Dooch's standard motor.

### Performance Curve

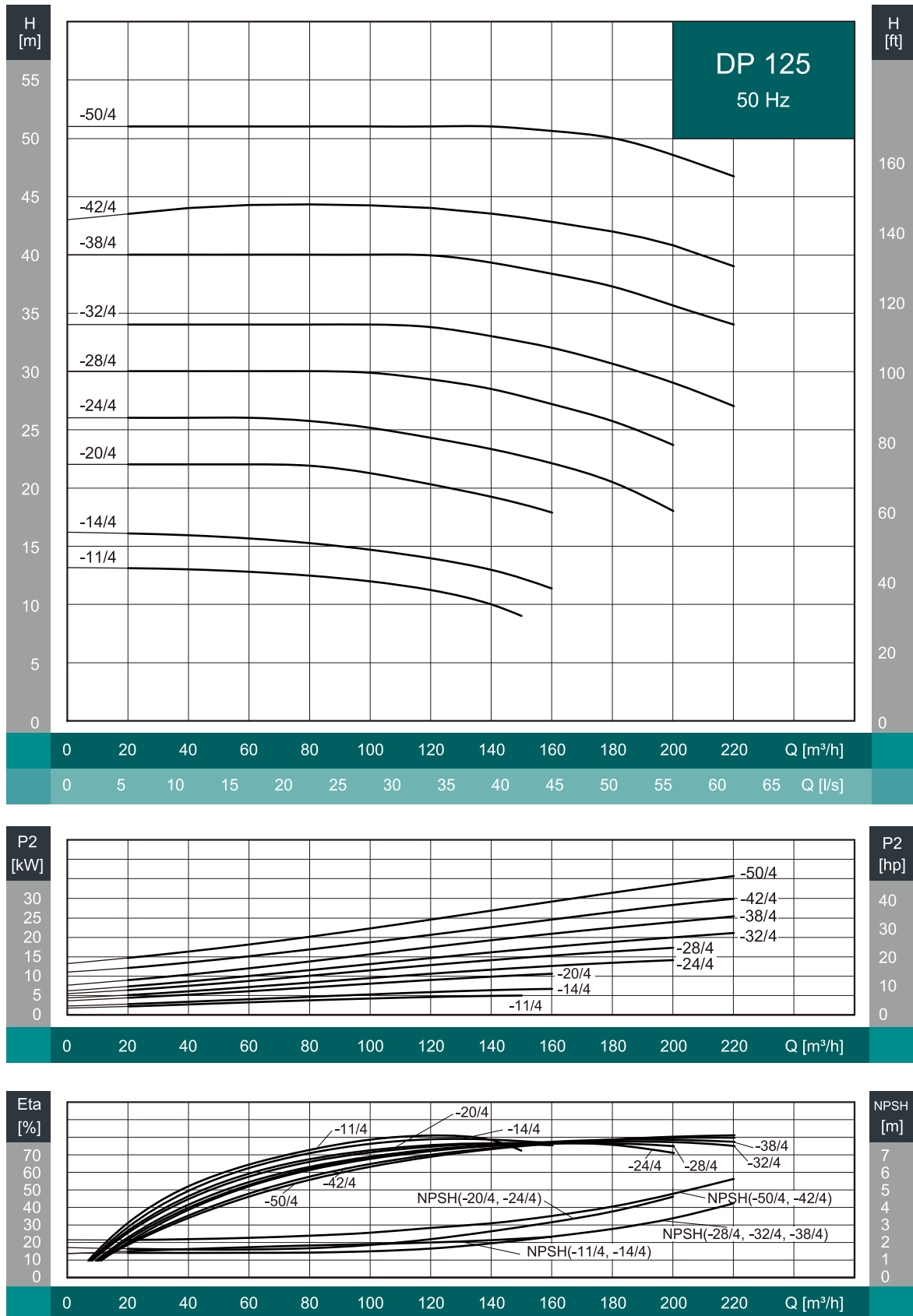

### Data Sheet

MODEL	POWER		Q (m <sup>3</sup> /hr)	20	40	60	80	100	120	140	150	160	180	200	220
	kW	HP													
DP125-11/4	5.5	7.5	HEAD (m)	13.5	13.4	13	12.5	12	11	10	9				
DP125-14/4	7.5	10		16.5	16	15.8	15.5	15	14	13	12	11			
DP125-20/4	11	15		22.3	22.5	22.3	22	21	20	19	19	18	16		
DP125-24/4	15	20		26.1	26.2	26	25.5	25	24	23	23	22	21	18	
DP125-28/4	18.5	25		30	30.3	30.5	30.2	30	29	28	27	26	25	24	
DP125-32/4	22	30		34	34.5	34.9	34.9	34.7	34	33	32	31.5	31	29	27
DP125-38/4	30	40		40.3	40.6	40.9	41	40.5	40	39	38	37.5	37	36	34
DP125-42/4	37	50		44.5	45.2	45.3	45.3	45	44.5	44	43.5	43	42	40	39
DP125-50/4	45	60		52.7	53	53.2	53.5	53.4	53	52.5	52	51	50	49	48

### Installation Sketch

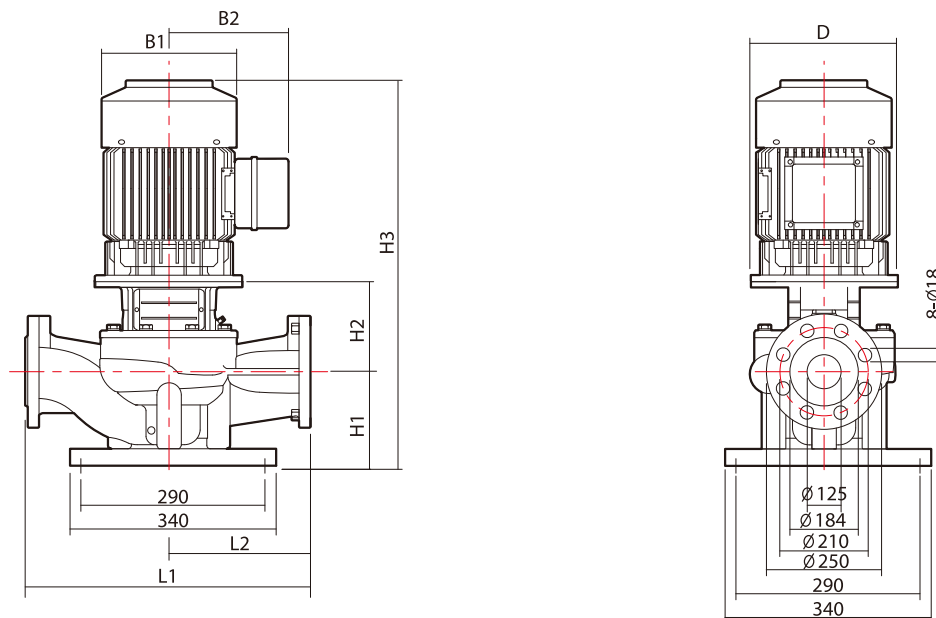

### Dimension / Weight

MODEL	DIMENSION (mm)								WEIGHT (kg)
	D	B1	B2	H1	H2	H3	L1	L2	
DP125-11/4	200	260	215	215	227.5	825.5	620	310	184
DP125-14/4	200	260	215	215	227.5	863.5	620	310	187
DP125-20/4	350	320	260	215	299	1019	800	400	342
DP125-24/4	350	320	260	215	299	1074	800	400	352
DP125-28/4	350	355	280	215	299	1092	800	400	376
DP125-32/4	350	355	280	215	299	1130	800	400	411
DP125-38/4	400	400	305	215	301	1176	800	400	476
DP125-42/4	450	450	330	215	319	1234	800	400	501
DP125-50/4	450	450	330	215	319	1259	800	400	538

Remark | The motor specification is based on Dooch's standard motor.

### Performance Curve

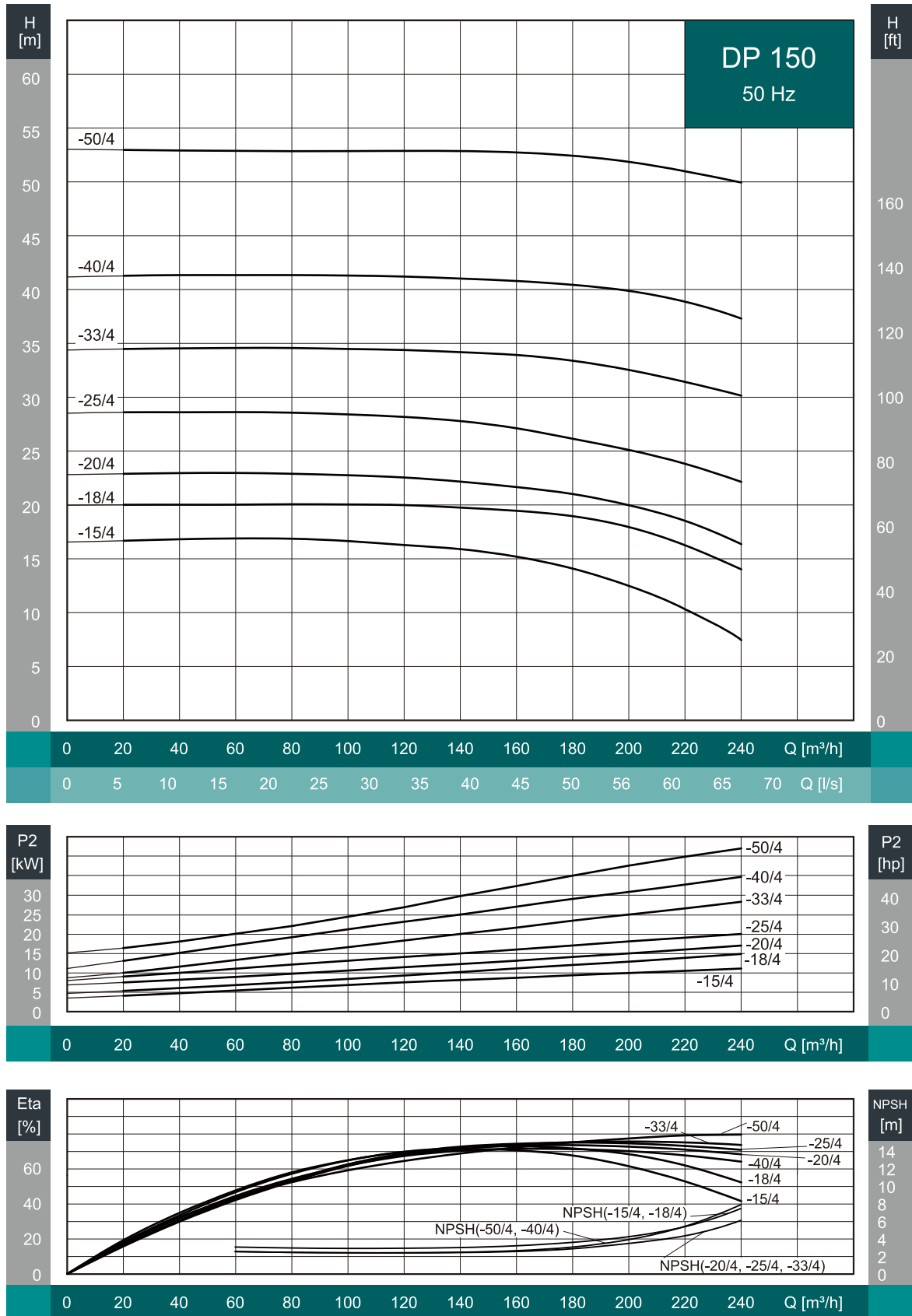

## Data Sheet

MODEL	POWER		Q (m <sup>3</sup> /hr)	20	40	60	80	100	120	140	160	180	200	220	240
	kW	HP													
DP150-15/4	11	15	HEAD (m)	20.1	20	19.5	19	18.5	18	17.5	16	14.5	12.5	10	7
DP150-18/4	15	20		20	20.1	20.4	20.5	20.2	19.8	19.3	18.7	18	17	16	14.2
DP150-20/4	18.5	25		23.7	23.9	24	23.8	23.4	22.9	22.3	21.6	20.8	20	18.9	16.8
DP150-25/4	22	30		27.6	27.9	28.2	28.3	28.1	27.7	27.1	26.3	26.2	25	23.9	22.6
DP150-33/4	30	40		34.5	34.6	34.7	34.8	34.7	34.6	34.4	34	33.7	33	32	30.8
DP150-40/4	37	50		42.3	42.5	42.6	42.7	42.6	42.4	42	41.5	40.8	40	39.2	37
DP150-50/4	45	60		53.1	53.2	53	52.8	52.7	52.6	52.5	52.4	52.3	52	51	49

## Installation Sketch

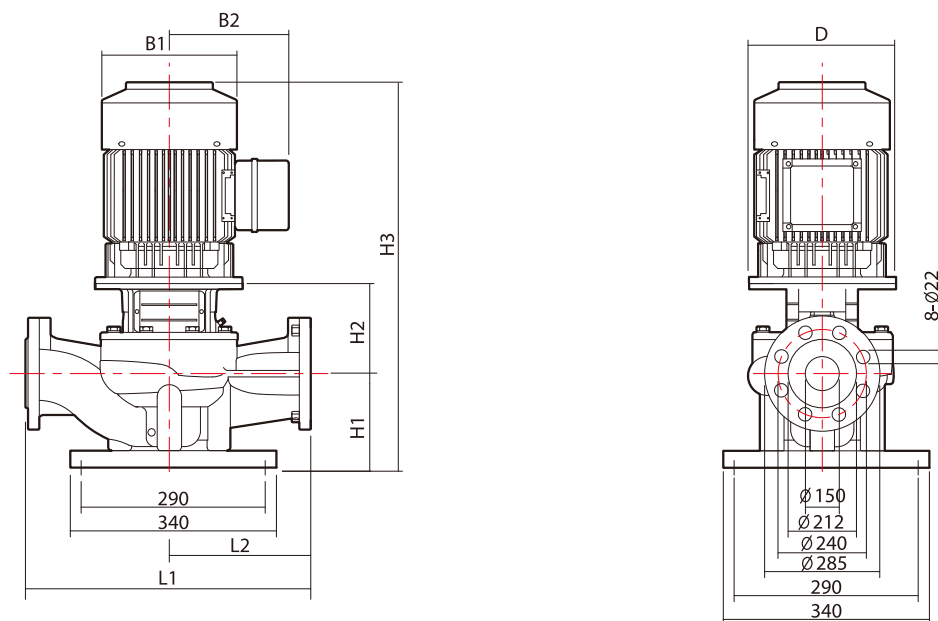

## Dimension / Weight

MODEL	DIMENSION (mm)								WEIGHT (kg)
	D	B1	B2	H1	H2	H3	L1	L2	
DP150-15/4	350	320	260	215	268	988	800	400	307
DP150-18/4	350	320	260	215	268	1043	800	400	328
DP150-20/4	350	355	280	215	268	1061	800	400	370
DP150-25/4	350	355	280	215	268	1099	800	400	380
DP150-33/4	400	400	305	215	268	1143	800	400	442
DP150-40/4	450	450	330	230	295	1195	900	450	545
DP150-50/4	450	450	330	230	295	1220	900	450	600

Remark | The motor specification is based on Dooch's standard motor.

### Performance Curve

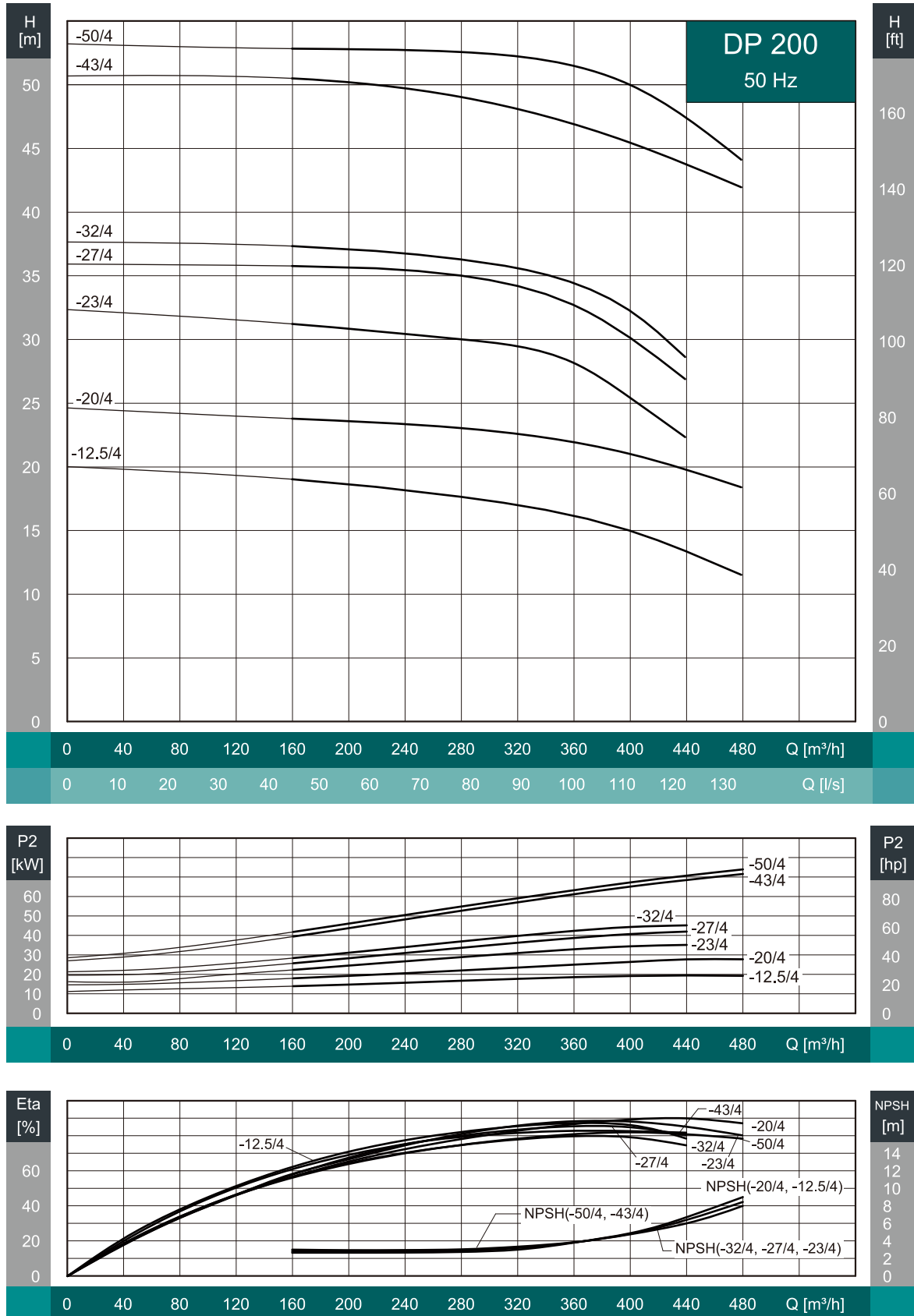

### Data Sheet

MODEL	POWER		Q (m <sup>3</sup> /hr)	160	200	240	280	320	360	400	440	480
	kW	HP										
DP200-12.5/4	22	30	HEAD (m)	18.4	18.2	18	17.5	17	16	14	13.5	8
DP200-20/4	30	40		24.6	24.4	24	23.6	22.8	21.7	20	17.5	14.2
DP200-23/4	37	50		31.7	31.5	31	30.5	30	29	25	22	18
DP200-27/4	45	60		35.6	35.5	35.4	35	34.5	33	30	27	22.5
DP200-32/4	55	75		37.5	37	36.5	35.7	34.7	33.3	32	29.9	27.7
DP200-43/4	75	100		50.4	50.5	51.25	51	50.5	50	45	43	42
DP200-50/4	90	120		52.9	52.8	52.6	52	51.5	51	50	48	45.5

### Installation Sketch

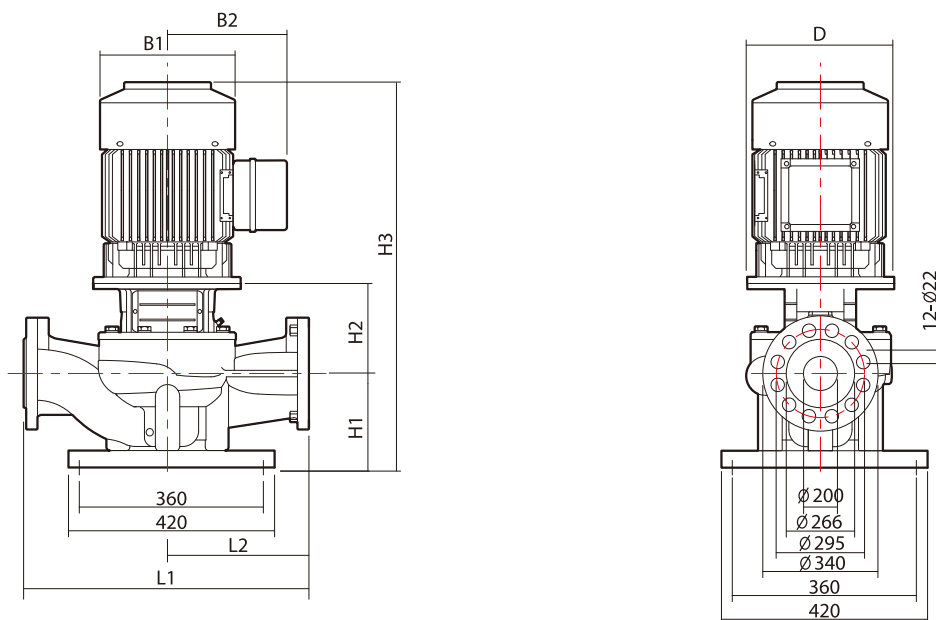

### Dimension / Weight

MODEL	DIMENSION (mm)								WEIGHT (kg)
	D	B1	B2	H1	H2	H3	L1	L2	
DP200-12.5/4	350	355	280	270	415	1301	1000	500	567
DP200-20/4	400	400	305	270	415	1345	1000	500	627
DP200-23/4	450	550	330	270	450	1390	1100	550	737
DP200-27/4	450	550	330	270	450	1415	1100	550	773
DP200-32/4	550	490	365	270	450	1490	1100	550	845
DP200-43/4	550	550	400	270	454	1594	1100	550	1018
DP200-50/4	550	550	400	270	454	1644	1100	550	1110

Remark | The motor specification is based on Dooch's standard motor.

### Performance Curve

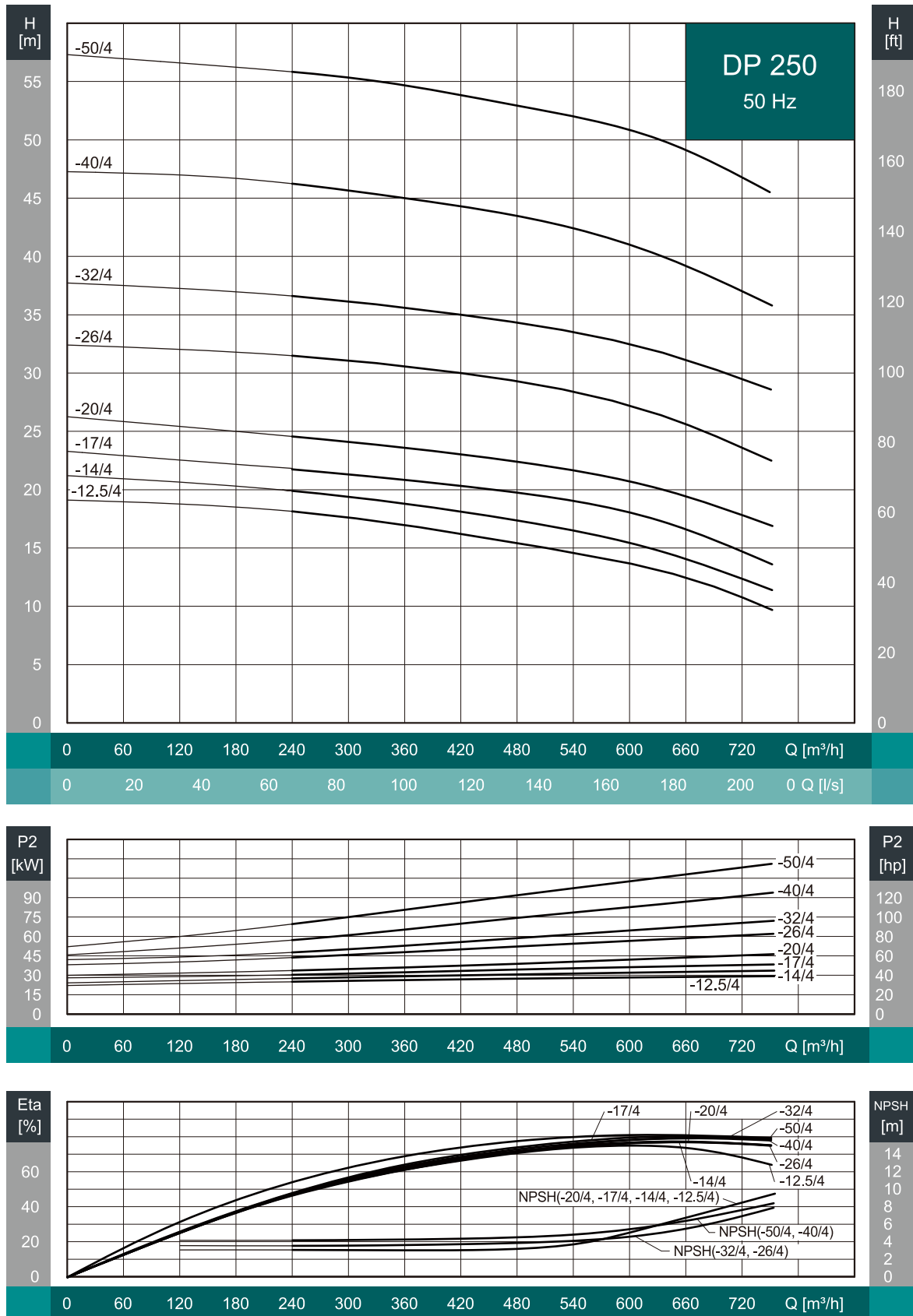



## Data Sheet

MODEL	POWER		Q (m <sup>3</sup> /hr)	240	300	360	420	480	540	600	630	660	720	750
	kW	HP												
DP250-12.5/4	30	40	HEAD (m)	18.4	17.9	17.2	16.4	15.5	14.5	13.2	12.5	11.8	9.9	8.7
DP250-14/4	37	50		20	19.5	18.9	18.2	17.5	16.6	15.6	14	13.4	12.6	11.6
DP250-17/4	45	60		21.8	21.3	20.8	20.1	19.4	18.6	17.6	17	16.3	14.4	13.4
DP250-20/4	55	75		24.5	24.1	23.7	23.1	22.4	21.5	20.5	20	19.3	17.6	16.5
DP250-26/4	75	100		31.7	31.1	30.6	29.9	29.1	28.2	26.8	26	25.2	23.1	21.9
DP250-32/4	90	120		36.7	36.3	35.7	35.1	34.3	33.5	32.6	32	31.3	29.5	28.4
DP250-40/4	110	150		46	45.5	44.9	44.2	43.4	42.3	40.8	40	39.1	36.8	35.5
DP250-50/4	132	180		55.6	55.2	54.6	53.9	53.2	52.3	50.9	50	49	46.7	45.4

## Installation Sketch

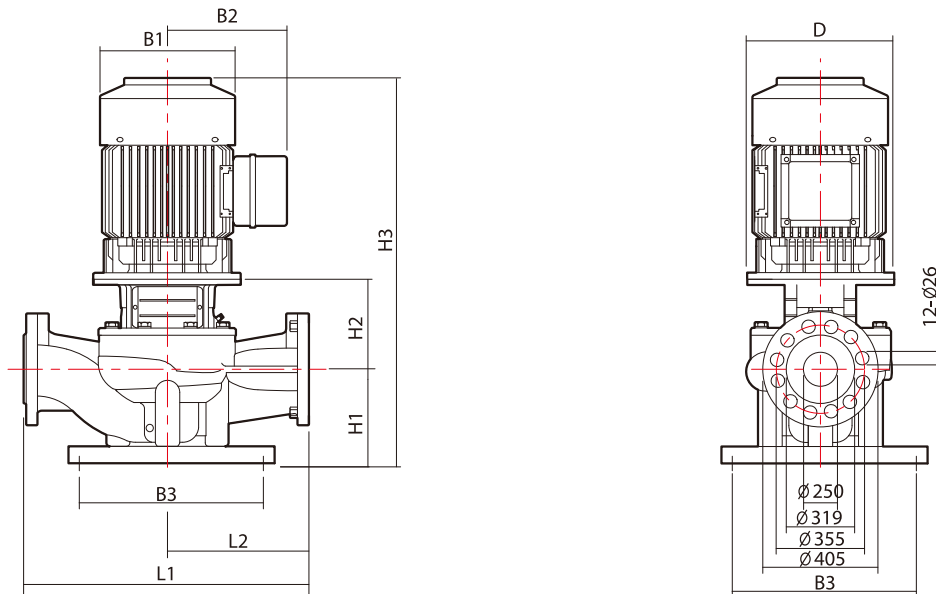

## Dimension / Weight

MODEL	DIMENSION (mm)									WEIGHT (kg)
	D	B1	B2	B3	H1	H2	H3	L1	L2	
DP250-12.5/4	400	400	305	390	300	465	1415	1100	550	672
DP250-14/4	450	450	335	390	300	495	1475	1100	550	733
DP250-17/4	450	450	335	390	300	495	1500	1100	550	769
DP250-20/4	550	490	365	390	300	495	1585	1100	550	842
DP250-26/4	550	550	400	440	300	507	1667	1100	550	1029
DP250-32/4	550	550	400	440	300	507	1717	1100	550	1119
DP250-40/4	660	625	555	440	305	525	1860	1200	600	1539
DP250-50/4	660	625	555	440	305	525	1910	1200	600	1623

Remark | The motor specification is based on Dooch's standard motor.

## XQP SERIES

Individual VFD Booster Pump System

Max. Flow (Q) : 720m<sup>3</sup>/h  
Max. Head (H) : 245m  
Motor Power : 0.75~22kW (1~30HP)



## NSQ SERIES

Individual VFD Booster Pump System

Max. Flow (Q) : 720m<sup>3</sup>/h  
Max. Head (H) : 245m  
Motor Power : 0.75~22kW (1~30HP)



## MQ SERIES

Multi-Inverter Booster Pump System

Max. Flow (Q) : 720m<sup>3</sup>/h  
Max. Head (H) : 245m  
Motor Power : 0.75~22kW (1~30HP)



## N747D SERIES

Inverter within Panel Booster Pump

Max. Flow (Q) : 720m<sup>3</sup>/h  
Max. Head (H) : 330m  
Motor Power : 0.75~45kW (1~60HP)



## XQ-XR(L) SERIES

Built-In Inverter Multi-stage Vertical Pump

Max. Flow (Q) : 120m<sup>3</sup>/h  
Max. Head (H) : 245m  
Motor Power : 0.75~22kW (1~30HP)



## XR(L) SERIES

Multi-Stage Vertical Pump

Max. Flow (Q) : 120m<sup>3</sup>/h  
Max. Head (H) : 330m  
Motor Power : 0.37~45kW  
(0.5~60HP)

# TOTAL PUMP SOLUTION

## SQ-2DHM SERIES

Built-In VFD Horizontal Booster Pump

Max. Flow (Q) : 36m<sup>3</sup>/h  
Max. Head (H) : 29m  
Motor Power : 0.75~1.1kW (1~1.5HP)



## NSQ-DHF(T) SERIES

Built-In VFD Multi-stage Horizontal Pump

Max. Flow (Q) : 29m<sup>3</sup>/h  
Max. Head (H) : 68m  
Motor Power : 0.55~5.5kW (0.75~7.5HP)

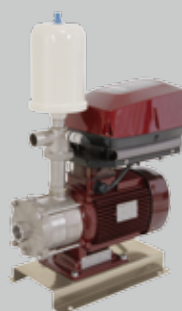

## SQ-DHM SERIES

Built-In VFD Horizontal Unistage Pump

Max. Flow (Q) : 18m<sup>3</sup>/h  
Max. Head (H) : 29m  
Motor Power : 0.75~1.1kW (1~1.5HP)



## NSQP-DHF(T) SERIES

Built-In VFD Horizontal Booster Pump System

Max. Flow (Q) : 58m<sup>3</sup>/h  
Max. Head (H) : 68m  
Motor Power : 0.55~5.5kW (0.75~7.5HP)



## NDS SERIES

Submersible Drainage and Sewage Pump

Max. Flow (Q) : 31m<sup>3</sup>/h  
Max. Head (H) : 20.7m  
Motor Power : 0.4~1.5kW (0.5~2HP)



## NSQ-XR(L) SERIES

Built-In Inverter Multi-stage Vertical Pump

Max. Flow (Q) : 130m<sup>3</sup>/h  
Max. Head (H) : 245m  
Motor Power : 0.75~22kW (1~30HP)



## NSQ-DP SERIES

Built-In VFD In-line Circulation Pump

Max. Flow (Q) : 480m<sup>3</sup>/h  
Max. Head (H) : 83m  
Motor Power : 0.75~22kW  
(1~30HP)



## DP SERIES

In-Line Circulation Pump

Max. Flow (Q) : 750m<sup>3</sup>/h  
Max. Head (H) : 85m  
Motor Power : 1.1~132kW  
(1.5~180HP)



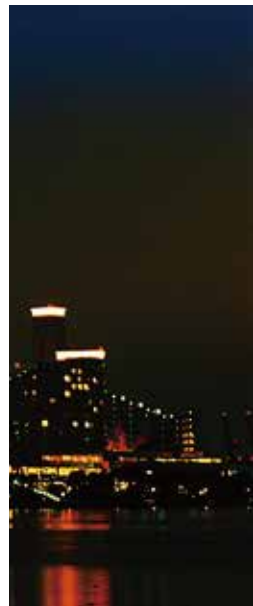
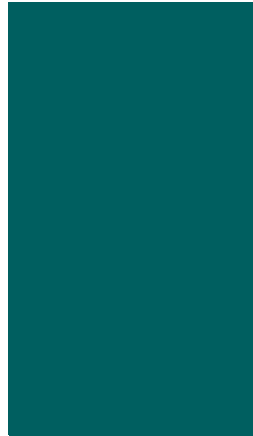

**GLOBAL BUSINESS CENTER**

2F~4F 162 LS-ro, Gunpo-si, Gyeonggi-do, Korea  
TEL: +82-31-831-1243  
FAX: +82-31-831-1250

**FACTORY**

(Sagok-Ri 295) 332 Hwagok-ro, Jangan-myeon, Hwaseong-si, Gyeonggi-do, Korea  
TEL: +82-31-831-1242  
FAX: +82-31-831-1250

**SHANGHAI DOOCH**

No. B3-6 Liantang road, Liantan industrial town, Qingpu, Shanghai, China  
TEL: +86-21-6767-9390  
FAX: +86-21-6767-9396

[www.doochpump.com](http://www.doochpump.com)

